

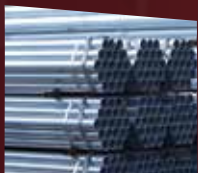

PRODUCT CATALOGUE

www.gulfbuildingonline.com





PROFILE

DSS STEEL LLC, formerly known as Dayal Steel Suppliers LLC, is a fully owned subsidiary of reputable Taurani Holdings Ltd. Established in 1976 as a medium sized building material company, DSS STEEL has evolved as one of the most recognized enterprises in the steel industry with core business being import, export, stock and supply of Pipes, Tubes and Structural Steel products.

As an ISO:9001 certified company, DSS STEEL sources its Long and Flat products in various sizes and specifications from some of the world's most reputable manufactures, and procures Tubes and Pipes from its sister concern - Universal Tube and Plastic Industries (UTP), THL Tube and Pipe Industries LLC and KHK Scaffolding & Formwork Ltd. LLC. to provide its customers world class products at the most competitive prices.

The company has been proficiently catering to Oil & Gas, Water Treatment & Desalination, Construction and infrastructure, Pre-Engineering Building, Machine & Equipment, Marine, Shipbuilding & Ship Repair, Auto Body Fabrication and various other allied industries.

With its main offices and stocking/distribution facilities at Ras Al Khor industrial area and National Industries Park Dubai, the company is complemented by strong sales network in other GCC countries to efficiently service its vast client base across United Arab Emirates, Middle east and Africa.

QUALITY POLICY

We are **DSS STEEL** (Dayal Steel Suppliers LLC), DUBAI, committed to enhance our Customers' value with services that set industry standards for quality and performance.

We relentlessly strive to deliver the best and understand the value of continual improvement setting goals and objectives throughout the organization to ensure that we are meeting our customers' expectations with our services.

We will continually strive to improve upon the quality of our Services complying with the International Standards & Applicable legal and other statutory requirements"

ACCREDITATION



CERTIFICATE

The Certification Body
of TÜV SÜD Middle East L.L.C.

certifies that



DSS Steel FZE
UTP yard, Jebel Ali Free Zone
Dubai, United Arab Emirates

has established and applies
a Quality Management System for

**Stockiest and Trading of Pipes, Tubes, H.R Coil,
C.R Coil, G.I Coil & Structural Steels**
(Category: NACE 46.6)

An audit was performed, Report No. 50035
Proof has been furnished that the requirements
according to

ISO 9001:2015

are fulfilled.

The certificate is valid from **2022-02-27** until **2025-02-26**

Certificate Registration No. **ME 9K 0033/01 EIAC**



Dubai, 2022-02-28

BAA4 006021

TÜV SÜD
 CERTIFICATE ◆ ZERTIFIKAT ◆ 認證證書 ◆ СЕРТИФИКАТ ◆ CERTIFICADO ◆ شهادة





INDEX

Products
Page No.

HFIW Black & Galvanized Pipes

11

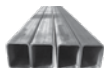

Square Hollow Sections

23



Rectangular Hollow Sections

29



Universal Beams

37

Universal Columns

44

American Wide Flange Beams

46

European Beams (HE/HEA)

64

European Beams (IPE)

70

European Beams (IPN)

76

JIS Wide Flange Shape

78

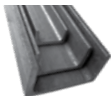

Mild Steel Channels

81

European Standard Channels (UPN)

83

Parallel Flange Channels (PFC)

85

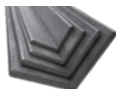

MS Equal Angles

87



MS Unequal Angles

93

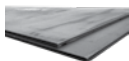

Hot Rolled Plates

98



MS Round & Square Bars

99

INDEX

	Products	Page No.
	MS Shafting/ Bright Bars	101
	MS Flats	103
	Coils & Sheets (Galvanized/ Cold Rolled/ Hot Rolled/ Aluminium)	108
	Chequered Plates	111
	Stainless Steel Products	112
	Stainless Steel Bright Wires	115
	Stainless steel Bright Bars	118
	GI Wires	120
	Mild Steel Gratings	122
	Expanded Metal	124

**BLACK & HOT DIPPED
GALVANIZED STEEL PIPES**

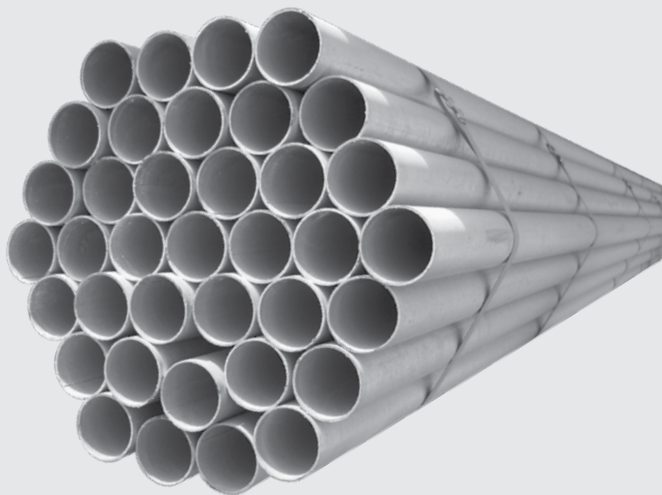

SPECIFICATION FOR STANDARD SIZES
EN 10255 : 2004 + A1 : 2007 FOR
BLACK AND HOT DIPPED GALVANIZED STEEL PIPES

Tube	Size		OD (Specified)		Wall Thickness (mm)	Weight of Tube (Kg./Mtr)		Pressure Bar
	Inch	NB	Min	Max		Black	S/S	
T Y P E - L	1/2"	15	21.0	21.7	2.3	1.08	1.09	50
	3/4"	20	26.4	27.1	2.3	1.40	1.41	50
	1"	25	33.2	34.0	2.9	2.20	2.22	50
	1 1/4"	32	41.9	42.7	2.9	2.82	2.85	50
	1 1/2"	40	47.8	48.6	2.9	3.25	3.29	50
	2"	50	59.6	60.7	3.2	4.51	4.58	50
	2 1/2"	65	75.2	76.0	3.2	5.75	5.87	50
	3"	80	87.9	88.7	3.2	6.76	6.93	50
	3 1/2"	90	100.3	101.2	3.6	8.70	8.88	50
	4"	100	113.0	113.9	3.6	9.83	10.1	50
	5"	125	138.5	140.8	4.5	15.00	15.5	50
6"	150	162.9	166.5	4.5	17.80	18.4	50	
T Y P E - L I	1/2"	15	21.0	21.7	2.3	1.08	1.09	50
	3/4"	20	26.4	27.1	2.3	1.39	1.40	50
	1"	25	33.2	34.0	2.9	2.20	2.22	50
	1 1/4"	32	41.9	42.7	2.9	2.82	2.85	50
	1 1/2"	40	47.8	48.6	2.9	3.24	3.28	50
	2"	50	59.6	60.7	3.2	4.49	4.56	50
	2 1/2"	65	75.2	76.0	3.2	5.73	5.85	50
	3"	80	87.9	89.4	3.6	7.55	7.72	50
4"	100	113.0	114.9	4.0	10.80	11.1	50	
T Y	1/2"	15	21.0	21.4	2.0	0.947	0.956	50
	3/4"	20	26.4	26.9	2.3	1.38	1.39	50



**SPECIFICATION FOR STANDARD SIZES
 EN 10255 : 2004 + A1 : 2007 FOR
 BLACK AND HOT DIPPED GALVANIZED STEEL PIPES**

Tube	Size		OD (Specified)		Wall Thickness (mm)	Weight of Tube (Kg./Mtr)		Pressure Bar
	Inch	NB	Min	Max		Black	S/S	
P E - L2	1"	25	33.2	33.8	2.6	1.98	2.00	50
	1 1/4"	32	41.9	42.5	2.6	2.54	2.57	50
	1 1/2"	40	47.8	48.4	2.9	3.23	3.27	50
	2"	50	59.6	60.2	2.9	4.08	4.15	50
	2 1/2"	65	75.2	76.0	3.2	5.71	5.83	50
	3"	80	87.9	88.7	3.2	6.72	6.89	50
	4"	100	113.0	113.9	3.6	9.75	10.00	50
M E D I U M	1/2"	15	21.1	21.8	2.6	1.21	1.22	50
	3/4"	20	26.5	27.3	2.6	1.56	1.57	50
	1"	25	33.3	34.2	3.2	2.41	2.43	50
	1 1/4"	32	42.0	42.9	3.2	3.10	3.13	50
	1 1/2"	40	47.9	48.8	3.2	3.56	3.6	50
	2"	50	59.7	60.8	3.6	5.03	5.1	50
	2 1/2"	65	75.3	76.6	3.6	6.42	6.54	50
	3"	80	88.0	89.5	4.0	8.36	8.53	50
	4"	100	113.1	115.0	4.5	12.2	12.5	50
	5"	125	138.5	140.8	5.0	16.6	17.1	50
6"	150	163.9	166.5	5.0	19.8	20.4	50	
H E A V Y	1/2"	15	21.1	21.8	3.2	1.44	1.45	50
	3/4"	20	26.5	27.3	3.2	1.87	1.88	50
	1"	25	33.3	34.2	4.0	2.93	2.95	50
	1 1/4"	32	42.0	42.9	4.0	2.79	3.82	50
	1 1/2"	40	47.9	48.8	4.0	4.37	4.41	50
	2"	50	59.7	60.8	4.5	6.19	6.26	50

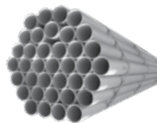

**SPECIFICATION FOR STANDARD SIZES
EN 10255 : 2004 + A1 : 2007 FOR
BLACK AND HOT DIPPED GALVANIZED STEEL PIPES.**

Tube	Size		OD (Specified)		Wall Thickness (mm)	Weight of Tube (Kg./Mtr)		Pressure Bar
	Inch	NB	Min	Max		Black	S/S	
	2 1/2"	65	75.3	76.6	4.5	7.93	8.05	50
	3"	80	88.0	89.5	5.0	10.3	10.5	50
	4"	100	113.1	115.0	5.4	14.5	14.8	50
	5"	125	138.5	140.8	5.4	17.9	18.4	50
	6"	150	163.9	166.5	5.4	21.3	21.9	50

- Tolerance** : As per the above table
- 1. Outside Diameter** : Straightness shall not exceed 0.002 L.
- 2. Straightness** : =7.5% on bundles of 10 tons or more, for M and H series and Type L
: -10% - 8% on individual tubes for Types L1 and L2.
- 3. Mass** : + 10% for M and H series & Types L
- 4. Thickness** : -8% with the plus tolerance limited by the mass tolerance for Types L1 and L2.
- 5. Ends** : Cut cleanly and nominally square with the axis of the tube and free from excessive burrs.
- 6. Chemical Composition** : % Max: C - 0.20%, Mn - 1.40%, S - 0.03% & P - 0.035%
- 7. Mechanical Properties** : UTS - 320 to 520 N/mm², YS - 195 N/mm² (minimum & %EL - 20 (minimum)



**SPECIFICATION FOR STANDARD SIZES
 EN 10255 : 2004 + A1 : 2007 FOR
 BLACK AND HOT DIPPED GALVANIZED STEEL PIPES.**

- 8. Flattening Test** :The flattening test shall be applied to bare tubes with specified outside diameter greater than 60.3mm.
 Welded tubes shall be flattened with the weld placed alternately at 0° or 90° to the direction of the Flattening force.
 :For Weld Test - Flatten up to 75% of original tube OD.No cracks in the weld.
 :For Material other than Weld-Flatten up to 60% of original tube OD. No cracks in the metal other than in the weld.

- 9. Bend Test** :Bend test up to 60.3mm OD. Radius at the bottom of the groove of the former shall be as per below table . The tubes shall show no cracks visible without magnifying aids.

Diameter (D)	21.3	26.9	33.7	42.4	48.3	60.3
Bending Radius	65	85	100	150	170	220

- 10. Leak Tightness Test** a) :On line NDT (Eddy Current)
 b) :Hydro testing at pressure as per above table and holding time min. 5 Second.

- 11. Zinc Coating** :As per EN 10240A1
 :For 1/2" to 3/4" - 14 TPI and from 1" to 6" - 11 TPI
 Check with standard ring and plug gauges.

- 12. Threading** :We can do on line stenciling as per this stanadr & as per customer needs at one meter interval

- 13. Marking** :We can do on line stenciling as per this stanadr & as per customer needs at one meter interval

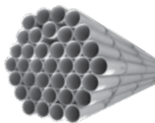

**SPECIFICATION FOR STANDARD SIZES
EN 10255 : 2004 + A1 : 2007 FOR
BLACK AND HOT DIPPED GALVANIZED STEEL PIPES.**

14. Packing : Hexagonal Type

15. Color Coading : For Type L --- Green
For Type L1 --- White
For Type L2 --- Brown
For Heavy --- Red
For Medium --- Blue

16. Mill Test Certificate We can issue a MTC, Certifying that the tubes supplied comply with this standard.



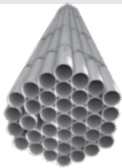

**SPECIFICATION FOR STANDARD SIZES
EXTRACTS FROM ASTM A53 GR-A SCHEDULE - 40
FOR BLACK AND GALVANIZED STEEL PIPES**

Designation		OD (Minimum)		OD (Maximum)		Wall Thickness		Weight Tube (Plain End)		Pressure E GrA	Weight of the (SS)		Pieces Per Bundle
Inch	NB(mm)	Inch	mm	Inch	mm	Inch	mm	Lb./Ft.	Kg./Mtr.	PSI	Lb./Ft.	Kg./Mtr.	
1/2"	15	0.822	20.90	0.854	21.70	0.109	2.77	0.850	1.27	700	0.860	1.27	120
3/4"	20	1.035	26.30	1.070	27.10	0.113	2.87	1.130	1.69	700	1.140	1.69	84
1"	25	1.300	33.00	1.330	33.80	0.133	3.38	1.680	2.50	700	1.690	2.50	60
1 1/4"	32	1.645	41.80	1.680	42.60	0.140	3.56	2.270	3.39	1200	2.280	3.40	42
1 1/2"	40	1.885	47.90	1.920	48.70	0.145	3.68	2.720	4.05	1200	2.740	4.04	36
2"	50	2.350	59.70	2.400	60.90	0.154	3.91	3.660	5.44	2300	3.680	5.46	26
2 1/2"	65	2.850	72.30	2.900	73.70	0.203	5.16	5.800	8.63	2500	5.850	8.67	18
3"	80	3.460	88.00	3.530	89.80	0.216	5.49	7.580	11.29	2220	7.680	11.35	14
3 1/2"	90	3.960	100.60	4.040	102.6	0.226	5.74	9.120	13.57	2030	9.270	13.71	12
4"	100	4.450	113.20	4.540	115.4	0.237	6.02	10.80	16.07	1900	10.920	16.23	10
5"	125	5.507	139.90	5.620	142.7	0.258	6.55	14.63	21.77	1670	14.900	22.07	7
6"	150	6.560	166.60	6.690	169.9	0.280	7.11	18.99	28.26	1520	19.340	28.58	7
8"	200	8.562	217.50	8.70	221.0	0.322	8.18	28.58	42.55	1340	--	--	4
10"	250	10.669	271.00	10.82	275.0	0.365	9.27	40.52	60.29	1220	--	--	4
12"	300	12.637	321.00	12.85	326.5	0.406	10.31	53.57	79.70	1150	--	--	2

SPECIFICATION FOR STANDARD SIZES EXTRACTS FROM ASTM A53 GR-A SCHEDULE - 40 FOR BLACK AND GALVANIZED STEEL PIPES

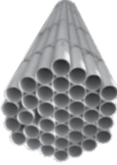

1. Tolerance	a) On Thickness	The minimum wall thickness at any point shall be not more than 12.5% under the specified wall thickness.
	b) On Diameter	For NPS 1 1/2" & under any point shall not vary more than ± 0.4 mm. For NPS 2" & above shall not vary more than $\pm 1\%$ from the standard specified
	c) Weight	The weight of the pipe shall not more than $\pm 10\%$ of the specified weight.
2. Internal Debeading	a) 1 1/2" and below size -	End finish shall be at the option of manufacturer which is nominally square cut with the axis of tube and free from excessive
	b) 2" and over size	Bevelled with ends beveled to an angle of 30, + 5 / -0 degree measured from a line perpendicular to the axis of the pipe with a root face of 1.6 mm ± 0.8 mm.
3. Internal Debeading	2" and above	Internal beads to be removed completely.
4. Chemical Composition (% Max)		C - 0.25%, Mn - 0.95%, S - 0.045%, P - 0.050%, Cu - 0.40%, Ni - 0.40%, Cr - 0.40%, Mo - 0.15% & V - 0.08% (Cu+Ni+Cr+Mo+V=1.0% max.)
5. Mechanical (Min)		Yield Strength-205 N/mm ² , Tensile Strength-330 N/mm ² , Elongation-24-36%
6. Bend Test	a)	Applicable to tubes upto and including nominal size of 50 mm When ordered for close coiling bend up to 180 degrees around a cylindrical mandrel, The diameter of which is 8 times the OD of pipe.
	b)	Bend up to 90 degree around a cylindrical mandrel, the diameter is 12 times the OD of pipe. : No Crack at any portion and no open in the weld.



**SPECIFICATION FOR STANDARD SIZES
EXTRACTS FROM ASTM A53 GR-A SCHEDULE - 40
FOR BLACK AND GALVANIZED STEEL PIPES**

8. Flattening Test	Applicable to tubes greater than nominal sizes of 50 mm & weld located 0/90 degree from line of direction of force. For weld ductility until 2/3 of outside dia of specimen tube. For ductility of steel until 1/3 of outside dia of specimen tube. Full flattening for testing of laminated and unsound material.
Stage -1 Stage -2 Stage -3	
8. Leak Tightness Test	a) On line NDT(Eddy Current) b) Hydro testing at pressure as per above Table and holding time Min. 5 second.
11. Black Varnish	Tubes are uniformly varnished externally over their full length.
10. Zinc Coating	Average 550 Gm/mm ² but one side should not be less than 490 Gm/mm ² . Free from bare Spot, Black spot, rough, overcoating, Peel off or any other surface defect.
11. Threading	For 1/2" & 3/4" - 14 Tpi, 1" To 2" - 11.5 Tpi And 2 1/2" To 6" - 8tpi. Check With Standard Astm Ring And Plug Gauges.
12. Marking	We can do on line stenciling as per this stanadrd & as per customer needs at one meter interval
13. Packing	Hexagonal Type
14. Mill Test Certificate	We can issue a MTC, certifying that the tubes supplied comply with this ASTM A 53 Standard

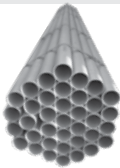

**SPECIFICATION FOR STANDARD SIZES
ASTM A53 GR-B SCHEDULE - 40 FOR
BLACK AND HOT DIPPED GALVANIZED STEEL PIPES**

Designation		OD (Minimum)		OD (Maximum)		Wall Thickness		Weight Tube (Plain End)		Pressure E Gr-A	Weight of the (SS)		Pieces Per Bundle
Inch	NB(mm)	Inch	mm	Inch	mm	Inch	mm	Lb./Ft.	Kg./Mtr.	PSI	Lb./Ft.	Kg./Mtr.	
1/2"	15	0.822	20.90	0.854	21.70	0.109	2.77	0.850	1.27	700	0.860	1.27	120
3/4"	20	1.035	26.30	1.070	27.10	0.113	2.87	1.130	1.69	700	1.140	1.69	84
1"	25	1.300	33.00	1.330	33.80	0.133	3.38	1.680	2.50	700	1.690	2.50	60
1 1/4"	32	1.645	41.80	1.680	42.60	0.140	3.56	2.270	3.39	1300	2.280	3.40	42
1 1/2"	40	1.885	47.90	1.920	48.70	0.145	3.68	2.720	4.05	1300	2.740	4.04	36
2"	50	2.350	59.70	2.400	60.90	0.154	3.91	3.660	5.44	2500	3.680	5.46	26
2 1/2"	65	2.850	72.30	2.900	73.70	0.203	5.16	5.800	8.63	2500	5.850	8.67	18
3"	80	3.460	88.00	3.530	89.80	0.216	5.49	7.580	11.29	2500	7.680	11.35	14
3 1/2"	90	3.960	100.60	4.040	102.6	0.226	5.74	9.120	13.57	2370	9.270	13.71	12
4"	100	4.450	113.20	4.540	115.4	0.237	6.02	10.80	16.07	2210	10.92	16.23	10
5"	125	5.507	139.90	5.620	142.7	0.258	6.55	14.63	21.77	1950	14.90	22.07	7
6"	150	6.560	166.60	6.690	169.9	0.280	7.11	18.99	28.26	1780	19.34	28.58	7
8"	200	8.562	217.50	8.70	221.0	0.322	8.18	28.58	42.55	1570	--	--	4
10"	250	10.669	271.00	10.82	275.0	0.365	9.27	40.52	60.29	1430	--	--	4
12"	300	12.637	321.00	12.85	326.5	0.406	10.31	53.57	79.70	1340	--	--	2

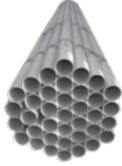

SPECIFICATION FOR STANDARD SIZES ASTM A53 GR-B SCHEDULE- 40 FOR BLACK AND HOT DIPPED GALVANIZED STEEL PIPES

1. Tolerance	<p>a) On Thickness The minimum wall thickness at any point shall be not more than 12.5% under the specified wall thickness.</p> <p>b) On Diameter For NPS 1 1/2" & under any point shall not vary more than ± 0.4 mm. For NPS 2" & above shall not vary more than $\pm 1\%$ from the standard specified</p> <p>c) On Weight The weight of the pipe shall not more than $\pm 10\%$ of the specified weight.</p>
2. Ends	<p>a) 1 1/2" and below size - End finish shall be at the option of manufacturer which is nominally square cut with the axis of tube and free from excessive burrs.</p> <p>b) 2" and over size Bevelled with ends beveled to an angle of 30, + 5 / -0 degree measured from a line perpendicular to the axis of the pipe with a root face of 1.6 mm ± 0.8 mm.</p>
3. Internal Debeading	Internal beads to be removed completely.
4. Heat Treatment	Weld Seam of the ERW Pipe in Grade B shall be heat treated after welding to a minimum temperature of 540° C, so that no untempered martensite remains
5. Chemical Composition (% Max)	C - 0.30%, Mn - 1.20%, S - 0.045%, P - 0.050%, Cu - 0.40%, Ni - 0.40%, Cr - 0.40%, Mo - 0.15% & V - 0.08% (Cu+Ni+Cr+Mo+V=1.0% max.)
6. Mechanical (Min)	Yield Strength-240 N/mm ² , Tensile Strength-415 N/mm ² , Elongation-19-30%
7. Bend Test	a) Applicable to tubes upto and including nominal size of 50 mm When order for close coiling bend up to 180 degrees around a cylindrical mandrel, The diameter of which is 8 times the OD of pipe.



**SPECIFICATION FOR STANDARD SIZES
ASTM A53 GR-B SCHEDULE - 40 FOR
BLACK AND HOT DIPPED GALVANIZED STEEL PIPES**

b)	<p>Bend up to 90 degree around a cylindrical mandrel, the diameter is 12 times the OD of pipe. No Crack at any portion and no open in the weld.</p>
8. Flattening Test	<p>Applicable to tubes greater than nominal sizes of 50 mm & weld located 0/90 degree from line of direction of force.</p> <p>Stage -1 For weld ductility until 2/3 of outside dia of specimen tube. Stage -2 For ductility of steel until 1/3 of outside dia of specimen tube. Stage -3 Full flattening for testing of laminated and unsound material.</p>
9. Leak Tightness Test	<p>a) On line NDT(Eddy Current) b) Hydro testing at pressure as per above Table and holding time Min. 5 second.</p>
10. Black Varnish	<p>Tubes are uniformly varnished externally over their full length.</p>
11. Zinc Coating	<p>Average 550 Gm/mm² but one side should not be less than 490 Gm/mm². Free from bare Spot,Black spot,rough,overcoating,Peel off or anyother surface defect.</p>
12. Threading	<p>For 1/2" & 3/4" - 14 Tpi, 1" To 2" - 11.5 Tpi And 2 1/2" To 6" - 8tpi. Check With Standard Astm Ring And Plug Gauges.</p>
13. Marking	<p>:We can do on line stenciling as per this stanadrd & as per customer needs at one meter interval</p>
14. Packing	<p>Hexagonal Type</p>
15. Mill Test Certificate	<p>We can issue a MTC, certifying that the tubes supplied comply with this ASTM A 53 Standard</p>

**SQUARE
HOLLOW SECTIONS**



SQUARE HOLLOW SECTIONS

EN 10219 - 1 & 2 : 2006

Size	Thickness	Mass
H x B mm	T mm	M kg/m
25 x 25	1.2	0.87
	1.5	1.06
	1.8	1.25
	2.0	1.36
	2.3	1.53
	2.5	1.64
	3.0	1.89
30 x 30	1.2	1.06
	1.5	1.30
	1.8	1.53
	2.0	1.68
	2.5	2.03
	3.0	2.36
	4.0	2.94
40 x 40	2.5	2.89
	3.0	3.41
	3.2	3.61
	4.0	4.39
	4.9	5.20
	5.0	5.28
50 x 50	2.5	3.68
	3.0	4.35
	3.2	4.62
	4.0	5.64
	4.9	6.74
	5.0	6.85
	6.0	7.99
60 x 60	3.0	5.29
	3.2	5.62
	4.0	6.90
	4.9	8.28

Size	Thickness	Mass	
H x B mm	T mm	M kg/m	
	5.0	8.42	
	6.0	9.87	
	6.3	10.3	
	8.0	12.5	
65 x 65	2.0	3.94	
	2.5	29.57	
	3.0	35.49	
70 x 70	3.0	6.24	
	3.2	6.63	
	3.6	7.40	
	4.0	8.15	
	4.9	9.81	
	5.0	9.99	
	6.0	11.8	
	6.3	12.3	
75 x 75	7.1	13.6	
	8.0	15.0	
	2.5	5.56	
	3.0	6.60	
80 x 80	4.0	8.59	
	5.0	10.50	
	6.0	12.30	
	3.2	7.63	
	3.6	8.53	
	4.0	9.41	
	4.9	11.4	
	5.0	11.6	
	5.6	12.8	
	6.0	13.6	

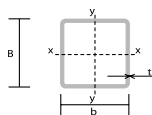
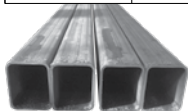

SQUARE HOLLOW SECTIONS

EN 10219 - 1 & 2 : 2006

Size	Thickness	Mass
H x B mm	T mm	M kg/m
	6.3	14.2
	7.1	15.8
90 x 90	3.6	9.66
	4.0	10.7
	4.9	12.9
	5.0	13.1
	5.6	14.6
	6.0	15.5
	6.3	16.2
	7.1	18.1
100 x 100	8.0	20.1
	3.6	10.8
	4.0	11.9
	4.9	14.4
	5.0	14.7
	5.6	16.3
	6.0	17.4
	6.3	18.2
	7.1	20.3
	8.0	22.6
120 x 120	10.0	27.4
	4.0	14.4
	4.9	17.5
	5.0	17.8
	5.6	19.9
	6.0	21.2
	6.3	22.2
	7.1	24.7
	8.0	27.6
	8.8	30.1
10.0	33.7	

Size	Thickness	Mass
H x B mm	T mm	M kg/m
	12.0	39.5
	12.5	40.9
125 x 125	2.5	9.49
	3.0	11.31
	4.0	14.90
	5.0	18.30
	6.0	21.70
	8.0	27.70
	9.0	30.60
	140 x 140	4.9
5.0		21.0
5.6		23.4
6.0		24.9
6.3		26.1
7.1		29.2
8.0		32.6
8.8		35.6
150 x 150	10.0	40.0
	12.0	47.0
	12.5	48.7
	4.9	22.1
	5.0	22.6
	5.6	25.1
	6.0	26.8
	6.3	28.1
7.1	31.4	
8.0	35.1	
8.8	38.4	
10.0	43.1	
12.0	50.8	

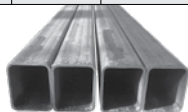
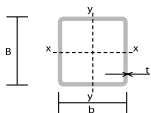

SQUARE HOLLOW SECTIONS

EN 10219 - 1 & 2 : 2006

Size	Thickness	Mass
H x B mm	T mm	M kg/m
160 x 160	12.5	52.7
	16.0††	65.2
	5.0	24.1
	5.6	26.9
	6.0	28.7
	6.3	30.1
	7.1	33.7
	8.0	37.6
	8.8	41.1
	10.0	46.3
180 x 180	5.0	27.3
	5.6	30.4
	6.0	32.5
	6.3	34.0
	7.1	38.1
	8.0	42.7
	8.8	46.7
	10.0	52.5
200 x 200	5.0	30.4
	5.6	33.9
	6.0	36.2

Size	Thickness	Mass
H x B mm	T mm	M kg/m
200 x 200	6.3	38.0
	7.1	42.6
	8.0	47.7
	8.8	52.2
	10.0	58.8
	12.0	69.6
	12.5	72.3
	14.2	81.1
250 x 250	5.0	38.3
	5.6	42.7
	6.0	45.7
	6.3	47.9
	12.5	91.9
	12.0	88.5
	14.2	103
	16.0	115
300 x 300	6.0	54.7
	8.0	72.8
	10.0	88.4
	12.0	109.2
	16.0	144.0
350 x 350	8.0	84.93
	10.0	106.0
	12.0	127.4
400 x 400	8.0	97.0
	10.0	121.3
	12.0	145.6
	16.0	194.7

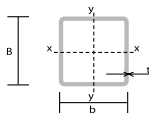
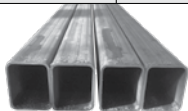

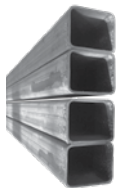

SPECIFICATION FOR STANDARD SIZES EN 10219-1 & 2:2006 SQUARE HOLLOW SECTIONS

Tolerances :		Square Hollow Sections					
Characteristic	Side Length (mm)	Tolerance					
Out Side Dimensions (B)	B<100	± 1% with a min. ± 0.5mm					
	100 3200	± 0.8%					
	B>200	± 0.6%					
Thickness	± 10% for thickness 5.0mm & ± 0.5mm for Thickness >5.0mm						
Concavity/ Convexity	Max. 0.8% with a min. of 0.5mm						
Squareness of Side	90° ± 1°						
External Corner Profile	-156.0mm - 1.6T to 2.4T,	6.0 <-1510.0mm - 2.0T to 3.0T,	T> 10.0mm - 2.4T to 3.6T				
Twist	2.0 mm + 0.5mm/m length						
Straightness	0.15% of total length and 3.0 mm over any 1m length						
Mass Per Unit Length	± 6% on individual delivered length						
Chemical Composition							
Grade	Chemical composition % max.						
	C	Si	Mn	P	S	N	Carbon Equivalent (CEV)
S235JRH	0.17	--	1.40	0.040	0.040	0.17	0.35
S275J0H	0.20	--	1.50	0.035	0.035	0.20	0.40
S275J2H	0.20	--	1.50	0.030	0.030	0.20	0.40

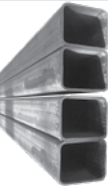

**SPECIFICATION FOR STANDARD SIZES
EN 10219-1&2:2006 SQUARE HOLLOW SECTIONS**

S355J0H	0.22	0.55	1.60	0.035	0.035	0.009	0.45
S355J2H	0.22	0.55	1.60	0.030	0.030	--	0.45

Carbon Equivalent : Max carbon equivalent shall be

$$CEV = C + (Mn / 6) + (Cr + Mo + V) / 5 + (Ni + Cu) / 15$$

MECHANICAL PROPERTIES

Grade	Min. Yield Strength Roh(Mpa)		Tensile Strength Rm (MPa)		Elongation % Min.			Min. Impact Energy(J)		
	Thk<3 mm		Th>.3 mm		-20°C			20°C		
S235JRH	235		360-510		24			--		
S275J0H	275		430-580		20			27		
S275J2H	275		430-580		20			--		
S355J0H	355		510-680		20			27		
S355J2H	355		510-680		20			--		

WORKMANSHIP -Free from overlap, Lamination,tool/roll marks,pin holes,open seam & other harmful defect.

PACKING-Box Type

MILL TEST CERTIFICATE -We can issue a MTC, Certifying that the tubes supplied comply with this standard.

**RECTANGULAR
HOLLOW SECTIONS**

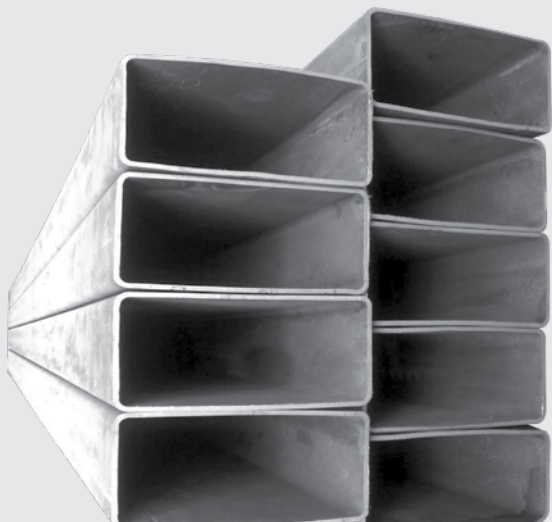

RECTANGULAR HOLLOW SECTIONS

EN 10219 - 1 & 2 : 2006

Size	Thickness	Mass
H x B mm	T mm	M kg/m
40 x 20	1.2	1.06
	1.5	1.30
	1.8	1.53
	2.0	1.68
	2.5	2.03
	3.0	2.36
50 x 25	1.5	1.65
	1.8	1.95
	2.0	2.15
	2.5	3.07
	3.0	3.88
	4.0	
50 x 30	2.5	2.89
	3.0	3.41
	3.2	3.61
	4.0	4.39
	4.9	5.20
	5.0	5.28
60 x 30	1.5	2.00
	1.8	2.38
	2.0	2.62
	2.5	3.21
	3.0	3.77
	4.0	4.83
60 x 40	2.5	3.68
	3.0	4.35
	3.2	4.62
	4.0	5.64
	4.9	6.74

Size	Thickness	Mass
H x B mm	T mm	M kg/m
	5.0	6.85
	6.0	7.99
	6.3	8.31
65 x 35	2.0	2.93
	2.5	3.60
	3.0	4.25
75 x 50	1.5	2.83
	1.8	3.37
	2.0	3.72
	2.5	4.58
	3.0	5.42
	4.0	7.02
80 x 40	5.0	8.52
	6.0	9.92
	3.0	5.29
	3.2	5.62
	4.0	6.90
	4.9	8.28
5.0	8.42	
6.0	9.87	
6.3	10.3	
8.0	12.5	

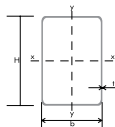

RECTANGULAR HOLLOW SECTIONS

EN 10219 - 1 & 2 : 2006

Size	Thickness	Mass
H x B mm	T mm	M kg/m
90 x 50	3.0	6.24
	3.2	6.63
	3.6	7.40
	4.0	8.15
	4.9	9.81
	5.0	9.99
	5.6	11.1
	6.0	11.8
	6.3	12.3
	7.1	13.6
8.0	15.0	
100x50	3.2	7.13
	3.6	7.96
	4.0	8.78
	4.9	10.6
	5.0	10.8
	6.0	12.7
	6.3	13.3
	7.1	14.7
	8.0	16.3
	100x60	3.0
3.2		7.63
3.6		8.53
4.0		9.41
4.9		11.4
5.0		11.6
5.6		12.8
6.0		13.6
6.3		14.2
7.1		15.8

Size	Thickness	Mass
H x B mm	T mm	M kg/m
120 x 60	8.0	17.5
	3.6	9.7
	4.0	10.7
	4.9	12.9
	5.0	13.1
	5.6	14.6
	6.0	15.5
	6.3	16.2
	7.1	18.1
	8.0	20.1
120 x 80	3.6	10.8
	4.0	11.9
	4.9	14.4
	5.0	14.7
	5.6	16.3
	6.0	17.4
	6.3	18.2
	7.1	20.3
	8.0	22.6
	10.0	27.4
125 x 75	2.5	7.53
	3.0	8.96
	4.0	11.70
	4.5	13.08
	5.0	14.40
	5.5	15.71
	6.0	17.00

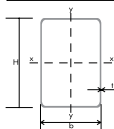

RECTANGULAR HOLLOW SECTIONS

EN 10219 - 1 & 2 : 2006

Size	Thickness	Mass
H x B mm	T mm	M kg/m
150 x 75	2.0	6.86
	2.5	8.51
	3.0	10.13
	4.0	13.30
	4.5	14.85
	5.0	16.37
	5.5	17.87
	6.0	19.09
8.0	21.53	
150 x 100	4.0	15.1
	4.9	18.3
	5.0	18.6
	5.6	20.7
	6.0	22.1
	6.3	23.1
	7.1	25.9
	8.0	28.9
	8.8	31.5
	10.0	35.3
	12.0	41.4
12.5	42.8	
160 x 80	4.0	14.4
	4.9	17.5
	5.0	17.8
	5.6	19.9
	6.0	21.2
	6.3	22.2
	7.1	24.7
	8.0	27.6
	8.8	30.1
	10.0	33.7

Size	Thickness	Mass	
H x B mm	T mm	M kg/m	
	12.0	39.5	
	12.5	40.9	
180 x 100	5.0	21.0	
	5.6	23.4	
	6.0	24.9	
	6.3	26.1	
	7.1	29.2	
	8.0	32.6	
	8.8	35.6	
	10.0	40.0	
	12.0	47.0	
	12.5	48.7	
	200 x 100	5.0	22.6
		5.6	25.1
		6.0	26.8
6.3		28.1	
7.1		31.4	
8.0		35.1	
8.8		38.4	
10.0		43.1	
12.0		50.8	
12.5		52.7	
14.2		58.9	
16.0††	65.2		
200 x 120	5.0	24.1	
	5.6	26.9	
	6.0	28.7	
	6.3	30.1	
	7.1	33.7	
	8.0	37.6	

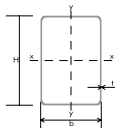

RECTANGULAR HOLLOW SECTIONS

EN 10219 - 1 & 2 : 2006

Size	Thickness	Mass
H × B mm	T mm	M kg/m
	8.8	41.1
	10.0	46.3
	12.0	54.6
	12.5	56.6
	14.2	63.3
	16.0	70.2
200 × 150	5.0	26.5
	5.6	29.5
	6.0	31.5
	6.3	33.0
	7.1	37.0
	8.0	41.4
	8.8	45.3
	10.0	51.0
	12.0	60.2
	12.5	62.5
	14.2	70.0
250 × 100	5.0	26.5
	5.6	29.5
	6.0	31.5
	6.3	33.0
	7.1	37.0
	8.0	41.4
	8.8	45.3
	10.0	51.0
	12.0	60.2
	12.5	62.5
	14.2	70.0
16.0	77.7	

Size	Thickness	Mass
H × B mm	T mm	M kg/m
250 × 150	5.0	30.4
	5.6	33.9
	6.0	36.2
	6.3	38.0
	7.1	42.6
	8.0	47.7
	8.8	52.2
	10.0	58.8
	12.0	69.6
	12.5	72.3
	14.2	81.1
260 × 140	5.0	30.4
	5.6	33.9
	6.0	36.2
	6.3	38.0
	7.1	42.6
	8.0	47.7
	8.8	52.2
	10.0	58.8
	12.0	69.6
	12.5	72.3
	14.2	81.1
300 × 100	5.0	30.4
	5.6	33.9
	6.0	36.2
	6.3	38.0
	7.1	42.6
	8.0	47.7

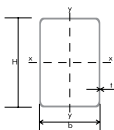

RECTANGULAR HOLLOW SECTIONS

EN 10219 - 1 & 2 : 2006

Size	Thickness	Mass
H x B mm	T mm	M kg/m
300 x 200	5.0	38.3
	5.6	42.7
	6.0	45.7
	6.3	47.9
	7.1	53.7
	8.0	60.3
	8.8	66.0
	10.0	74.5
	12.0	88.5
	12.5	91.9
	14.2	103
16.0	115	
400 x 200	6.0	55.1
	6.3	57.8
	7.1	64.9
	8.0	72.8
	8.8	79.8
	10.0	90.2
	12.0	107
16.0	141	
450 x 250	8.0	85.4
	10.0	106
	12.0	126
	16.0	166

Size	Thickness	Mass
H x B mm	T mm	M kg/m
400 x 300	8.0	85.4
	8.8	93.6
	10.0	106
	12.0	126
	12.5	131
	14.2	148
16.0	166	
500 x 300	8.0	97.0
	12.0	145.6
	16.0	194.7

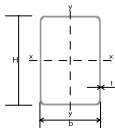



SPECIFICATION FOR STANDARD SIZES EN 10219-1 & 2:2006 RECTANGULAR HOLLOW SECTIONS

Tolerances :		Rectangular Hollow Sections
Characteristic	Side Length (mm)	Tolerance
Out Side Dimensions (B & H)	H, B < 100	± 1% with a min. ± 0.5mm
	100 < H, B < 200	± 0.8%
	H, B > 200	± 0.6%
Thickness	± 10% for thickness	5.0mm & ± 0.5mm for Thickness > 5.0mm
Concavity/ Convexity		Max. 0.8% with a min. of 0.5mm
Squareness Of Side		90° ± 1°
External Corner Profile	l - 56.0mm - 1.6T to 2.4T,	6.0 < l ≤ 10.0mm - 2.0T to 3.0T, T > 10.0mm - 2.4T to 3.6T
Twist		2.0 mm + 0.5mm/m length
STRAIGHTNESS	0.15% of total length and 3.0 mm over any 1m length	
MASS PER UNIT LENGTH	± 6% on individual delivered length	



SPECIFICATION FOR STANDARD SIZES EN 10219-1 & 2:2006 RECTANGULAR HOLLOW SECTIONS

Chemical Composition		Chemical composition % max.						
		C	Si	Mn	P	S	N	Carbon Equivalent (CEV)
Grade	S235JRH	0.17	--	1.40	0.040	0.040	0.009	0.35
	S275J0H	0.20	--	1.50	0.035	0.035	0.009	0.40
	S275J2H	0.20	--	1.50	0.030	0.030	--	0.40
	S355J0H	0.22	0.55	1.60	0.035	0.035	0.009	0.45
	S355J2H	0.22	0.55	1.60	0.030	0.030	--	0.45

Carbon Equivalent : Max carbon equivalent shall be
 $CEV = C + (Mn / 6) + (Cr + Mo + V) / 5 + (Ni + Cu) / 15$

MECHANICAL PROPERTIES

Grade	Yield Strength Ren (Mpa)		Tensile Strength Rm (MPa)		Elongation % Min.		Min. Impact Energy(J)		
	Min.	Thk<3 mm	Thk<3 mm	Th 1.3 mm	% Min.		-20°C	0°C	20°C
S235JRH	235	360-510	360-510	360-510	24		--	--	--
S275J0H	275	430-580	430-580	410-560	20		--	27	27
S275J2H	275	430-580	430-580	410-560	20		27	--	--
S355J0H	355	510-680	510-680	470-630	20		--	27	27
S355J2H	355	510-680	510-680	470-630	20		27	--	--

WORKMANSHIP-Free from overlap, Lamination, tool/roll marks, pin holes, open seam & other harmful defect.

PACKING-Box Type

MILL TEST CERTIFICATE- We can issue a MTC, Certifying that the tubes supplied comply with this standard.

UNIVERSAL BEAMS

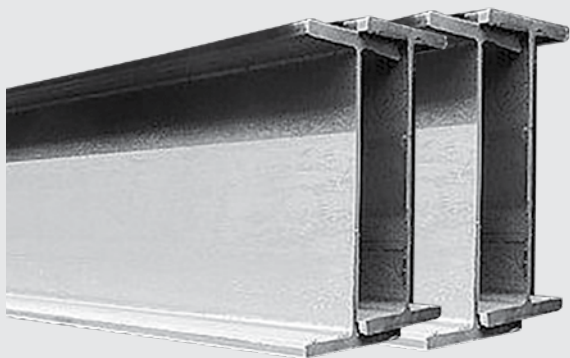

UNIVERSAL BEAMS - DIMENSIONS AND PROPERTIES

To BS 4 : Part 1993 : 1

Designation	Mass per Metre kg/m	Depth of Section h mm	Width of Section b mm	Thickness Web s mm	Thickness Flange t mm	Root Radius r mm	Depth Between Fillets d mm	Ratios for Local Buckling	
								Flange b/2t	Web d/s
127 x 76 x 13	13.0	127.0	76.0	4.0	7.6	7.6	96.6	5.00	24.1
152 x 89 x 16	16.0	152.4	88.7	4.5	7.7	7.6	121.8	5.76	27.1
178 x 102 x 19	19.0	177.8	101.2	4.8	7.9	7.6	146.8	6.41	30.6
203 x 102 x 23	23.1	203.2	101.8	5.4	9.3	7.6	169.4	5.47	31.4
203 x 133 x 25	25.1	203.2	133.2	5.7	7.8	7.6	172.4	8.54	30.2
203 x 133 x 30	30.0	206.8	133.9	6.4	9.6	7.6	172.4	6.97	26.9
254 x 102 x 22	22.0	254.0	101.6	5.7	6.8	7.6	225.2	7.47	39.5
254 x 102 x 25	25.2	257.2	101.9	6.0	8.4	7.6	225.2	6.07	37.5
254 x 102 x 28	28.3	260.4	102.2	6.3	10.0	7.6	225.2	5.11	35.7
254 x 146 x 31	31.1	251.4	146.1	6.0	8.6	7.6	219.0	8.49	36.5
254 x 146 x 37	37.0	256.0	146.4	6.3	10.9	7.6	219.0	6.72	34.8
254 x 146 x 43	43.0	259.6	147.3	7.2	12.7	7.6	219.0	5.80	30.4
305 x 102 x 25	24.8	305.1	101.6	5.8	7.0	7.6	275.9	7.26	47.6
305 x 102 x 28	28.2	308.7	101.8	6.0	8.8	7.6	275.9	5.78	46.0
305 x 102 x 33	32.8	312.7	102.4	6.6	10.8	7.6	275.9	4.74	41.8
305 x 127 x 37	37.0	304.4	123.3	7.1	10.7	8.9	265.2	5.77	37.4
305 x 127 x 42	41.9	307.2	124.3	8.0	12.1	8.9	265.2	5.14	33.2
305 x 127 x 48	48.1	311.0	125.3	9.0	14.0	8.9	265.2	4.47	29.5
305 x 165 x 40	40.3	303.4	165.0	6.0	10.2	8.9	265.2	8.09	44.2
305 x 165 x 46	46.1	306.6	165.7	6.7	11.8	8.9	265.2	7.02	39.6
305 x 165 x 54	54.0	310.4	166.9	7.9	13.7	8.9	265.2	6.09	33.6
356 x 127 x 33	33.1	349.0	125.4	6.0	8.5	10.2	311.6	7.38	51.9
356 x 127 x 39	39.1	353.4	126.0	6.6	10.7	10.2	311.6	5.89	47.2

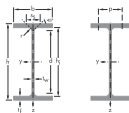

UNIVERSAL BEAMS - DIMENSIONS AND PROPERTIES

To BS 4 : Part 1 : 1993

Second Moment of Area		Radius of Gyration		Elastic Modulus		Plastic Modulus		Buckling Parameter U	Torsional Index x	Wrapping Constant H	Torsional Constant J	Area of Section
Axis x-x	Axis y-y	Axis x-x	Axis y-y	Axis x-x	Axis y-y	Axis x-x	Axis y-y					
cm ⁴	cm ⁴	cm	cm	cm ³	cm ³	cm ³	cm ³			dm ⁴	dm ⁴	dm ²
473	55.7	5.35	1.84	74.6	14.7	84.2	22.6	0.895	16.3	0.00199	16.3	16.3
834	89.8	6.41	2.10	109	20.2	123	31.2	0.890	19.6	0.00470	19.6	19.6
1356	137	7.48	2.37	153	27.0	171	41.6	0.888	22.6	0.00987	22.6	22.6
2105	164	8.46	2.36	207	32.2	234	49.8	0.888	22.5	0.0154	22.5	22.5
2340	308	8.56	3.10	230	46.2	258	70.9	0.877	25.6	0.0294	25.6	25.6
2896	385	8.71	3.17	280	57.5	314	88.2	0.881	21.5	0.0374	21.5	21.5
2841	119	10.1	2.06	224	23.5	259	37.3	0.856	36.4	0.0182	36.4	36.4
3415	149	10.3	2.15	266	29.2	306	46.0	0.866	31.5	0.0230	31.5	31.5
4005	179	10.5	2.22	308	34.9	353	54.8	0.874	27.5	0.0280	27.5	27.5
4413	448	10.5	3.36	351	61.3	393	94.1	0.880	29.6	0.0660	29.6	29.6
5537	571	10.8	3.48	433	78.0	483	119	0.890	24.3	0.0857	24.3	24.3
6544	677	10.9	3.52	504	92.0	566	141	0.891	21.2	0.103	21.2	21.2
4455	123	11.9	1.97	292	24.2	342	38.8	0.846	43.4	0.0273	43.4	43.4
5366	155	12.2	2.08	348	30.5	403	48.5	0.859	37.4	0.0349	37.4	37.4
6501	194	12.5	2.15	416	37.9	481	60.0	0.866	31.6	0.0442	31.6	31.6
7171	336	12.3	2.67	471	54.5	539	85.4	0.872	29.7	0.0725	29.7	29.7
8196	389	12.4	2.70	534	62.6	614	98.4	0.872	26.5	0.0846	26.5	26.5
9575	461	12.5	2.74	616	73.6	711	116	0.873	23.3	0.102	23.3	23.3
8503	764	12.9	3.86	560	92.6	623	142	0.889	31.0	0.164	31.0	31.0
9899	896	13.0	3.90	646	108	720	166	0.891	27.1	0.195	27.1	27.1
11700	1063	13.0	3.93	754	127	846	196	0.889	23.6	0.234	23.6	23.6
8249	280	14.0	2.58	473	44.7	543	70.3	0.863	42.2	0.0812	42.2	42.2
10170	358	14.3	2.68	576	56.8	659	891	0.871	35.2	0.105	35.2	35.2

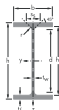

UNIVERSAL BEAMS - DIMENSIONS AND PROPERTIES

To BS 4 : Part 1 : 1993

Designation	Mass per Metre kg/m	Depth of Section h mm	Width of Section b mm	Thickness Web s mm	Thickness Flange t mm	Root Radius r mm	Depth Between Fillets d mm	Ratios for Local Buckling	
								Flange b/2t	Web d/s
356 x 171 x 45	45.0	351.4	171.1	7.0	9.7	10.2	311.6	8.82	44.5
356 x 171 x 51	51.0	355.0	171.5	7.4	11.5	10.2	311.6	7.46	42.1
356 x 171 x 57	57.0	358.0	172.2	8.1	13.0	10.2	311.6	6.62	38.5
356 x 171 x 67	67.1	363.4	173.2	9.1	15.7	10.2	311.6	5.52	34.2
406 x 140 x 39	39.0	398.0	141.8	6.4	8.6	10.2	360.4	8.24	56.3
406 x 140 x 46	46.0	403.2	142.2	6.8	11.2	10.2	360.4	6.35	53.0
406 x 178 x 54	54.1	402.6	177.7	7.7	10.9	10.2	360.4	8.15	46.8
406 x 178 x 60	60.1	406.4	177.9	7.9	12.8	10.2	360.4	6.95	45.6
406 x 178 x 67	67.1	409.4	178.8	8.8	14.3	10.2	360.4	6.25	41.0
406 x 178 x 74	74.2	412.8	179.5	9.5	16.0	10.2	360.4	5.61	37.9
457 x 152 x 52	52.3	449.8	152.4	7.6	10.9	10.2	407.6	6.99	53.6
457 x 152 x 60	59.8	454.6	152.9	8.1	13.3	10.2	407.6	5.75	50.3
457 x 152 x 67	67.2	458.0	153.8	9.0	15.0	10.2	407.6	5.13	45.3
457 x 152 x 74	74.2	462.0	154.4	9.6	17.0	10.2	407.6	4.54	42.5
457 x 152 x 82	82.1	465.8	155.3	10.5	18.9	10.2	407.6	4.11	38.8
457 x 191 x 67	67.1	453.4	189.9	8.5	12.7	10.2	407.6	7.48	48.0
457 x 191 x 74	74.3	457.0	190.4	9.0	14.5	10.2	407.6	6.57	45.3
457 x 191 x 82	82.0	460	191.3	9.9	16.0	10.2	407.6	5.98	41.2
457 x 191 x 89	89.3	463.4	191.9	10.5	17.7	10.2	407.6	5.42	38.8
457 x 191 x 98	98.3	467.2	192.8	11.4	19.6	10.2	407.6	4.92	35.8
533 x 210 x 82	82.2	528.3	208.8	9.6	13.2	12.7	476.5	7.91	49.6
533 x 210 x 92	92.1	533.1	209.3	10.1	15.6	12.7	476.5	6.71	47.2
533 x 210 x 101	101.0	536.7	210.0	10.8	17.4	12.7	476.5	6.03	44.1
533 x 210 x 109	109.0	539.5	210.8	11.6	18.8	12.7	475.5	5.61	41.1
533 x 210 x 122	122.0	544.5	211.9	12.7	21.3	12.7	476.5	4.97	37.5
610 x 229 x 101	101.2	602.6	227.6	10.5	14.8	12.7	547.6	7.69	52.2
610 x 229 x 113	113.0	607.6	228.2	11.1	17.3	12.7	547.6	6.60	49.3
610 x 229 x 125	125.1	612.2	229.0	11.9	19.6	12.7	547.6	5.84	46.0
610 x 229 x 140	139.9	617.2	230.2	13.1	22.1	12.7	547.6	5.21	41.8

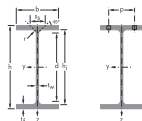

UNIVERSAL BEAMS - DIMENSIONS AND PROPERTIES

To BS 4 : Part 1993 : I

Second Moment of Area		Radius of Gyration		Elastic Modulus		Plastic Modulus		Buckling Parameter U	Torsional Index x	Wrapping Constant H	Torsional Constant J	Area of Section
Axis x-x	Axis y-y	Axis x-x	Axis y-y	Axis x-x	Axis y-y	Axis x-x	Axis y-y					
cm ⁴	cm ⁴	cm	cm	cm ³	cm ³	cm ³	cm ³			dm ⁴	dm ⁴	dm ²
12070	811	14.5	3.76	687	94.8	775	147	0.874	36.8	0.237	15.8	0.237
14140	968	14.8	3.86	796	113	896	174	0.881	32.1	0.286	23.8	0.286
16040	1108	14.9	3.91	896	129	1010	199	0.882	28.8	0.330	33.4	0.330
19460	1362	15.1	3.99	1071	157	1211	243	0.886	24.4	0.412	55.7	0.412
12510	410	15.9	2.87	629	57.8	724	90.8	0.858	47.5	0.155	10.7	0.155
15690	538	16.4	3.03	778	75.7	888	118	0.871	38.9	0.207	19.0	0.207
18720	1021	16.5	3.85	930	115	1055	178	0.871	38.3	0.392	23.1	0.392
21600	1203	16.8	3.97	1063	135	1199	209	0.880	33.8	0.466	33.3	0.466
24330	1365	16.9	3.99	1189	153	1346	237	0.880	30.5	0.533	46.1	0.533
27310	1545	17.0	4.04	1323	172	1501	267	0.882	27.6	0.608	62.8	0.608
21370	645	17.9	3.11	950	84.6	1096	133	0.859	43.9	0.311	21.4	0.311
25500	795	18.3	3.23	1122	104	1287	163	0.868	37.5	0.387	33.8	0.387
28930	913	18.4	3.27	1263	119	1453	187	0.869	33.6	0.448	47.7	0.448
32670	1047	18.6	3.33	1414	136	1627	213	0.873	30.1	0.518	65.9	0.518
36590	1185	18.7	3.37	1571	153	1811	240	0.873	27.4	0.591	89.2	0.591
29380	1452	18.5	4.12	1296	153	1471	237	0.872	37.9	0.705	37.1	0.705
33320	1671	18.8	4.20	1458	176	1653	272	0.877	33.9	0.818	51.8	0.818
37050	1871	18.8	4.23	1611	196	1831	304	0.877	30.9	0.922	69.2	0.922
41020	2089	19.0	4.29	1770	218	2014	338	0.880	28.3	1.04	90.7	1.04
45730	2347	19.1	4.33	1957	243	2232	379	0.881	25.7	1.18	121	1.18
47540	2007	21.3	4.38	1800	192	2059	300	0.864	41.6	1.33	51.5	1.33
55230	2389	21.7	4.51	2072	228	2360	356	0.872	36.5	1.60	75.7	1.60
61520	2692	21.9	4.57	2292	256	2612	399	0.874	33.2	1.81	101	1.81
66820	2943	21.9	4.60	2477	279	2828	436	0.875	30.9	1.99	126	1.99
76040	3388	22.1	4.67	2793	320	3196	500	0.877	27.6	2.32	178	2.32
75780	2915	24.2	4.75	2515	256	2881	400	0.864	43.1	2.52	77	2.52
87320	3434	24.6	4.88	2874	301	3281	469	0.870	38.0	2.99	111	2.99
98610	3932	24.9	4.97	3221	343	3676	535	0.873	34.1	3.45	154	3.45
111800	4505	25.0	5.03	3622	391	4142	611	0.875	30.6	3.99	216	3.99

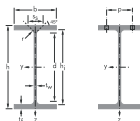

UNIVERSAL BEAMS - DIMENSIONS AND PROPERTIES

To BS 4 : Part 1 : 1993

Designation	Mass per Metre kg/m	Depth of Section h mm	Width of Section b mm	Thickness Web s mm	Thickness Flange t mm	Root Radius r mm	Depth Between Fillets d mm	Ratios for Local Buckling	
								Flange b/2t	Web d/s
610 x 305 x 149	149.1	612.4	304.8	11.8	19.7	16.5	540.0	7.74	45.8
610 x 305 x 179	179.0	620.2	307.1	14.1	23.6	16.5	540.0	6.51	38.3
610 x 305 x 238	238.1	635.8	311.4	18.4	31.4	16.5	540.0	4.96	29.3
686 x 254 x 125	125.2	677.9	253.0	11.7	16.2	15.2	615.1	7.81	52.6
686 x 254 x 140	140.1	683.5	253.7	12.4	19.0	15.2	615.1	6.68	49.6
686 x 254 x 152	152.4	687.5	254.5	13.2	21.0	15.2	615.1	6.06	46.6
686 x 254 x 170	170.2	692.9	255.8	14.5	23.7	15.2	615.1	5.40	42.4
762 x 267 x 134	133.9	750.0	264.4	12.0	15.5	16.5	686.0	8.53	57.2
762 x 267 x 147	146.9	754.0	265.2	12.8	17.5	16.5	686.0	7.58	53.6
762 x 267 x 173	173.0	762.2	266.7	14.3	21.6	16.5	686.0	6.17	48.0
762 x 267 x 197	196.8	769.8	268.0	15.6	25.4	16.5	686.0	5.28	44.0
838 x 292 x 176	175.9	834.9	291.7	14.0	18.8	17.8	761.7	7.76	54.4
838 x 292 x 194	193.8	840.7	292.4	14.7	21.7	17.8	761.7	6.74	51.8
838 x 292 x 226	226.5	850.9	293.8	16.1	26.8	17.8	761.7	5.48	47.3
914 x 305 x 201	200.9	903.0	303.3	15.1	20.2	19.1	824.4	7.51	54.6
914 x 305 x 224	224.2	910.4	304.1	15.9	23.9	19.1	824.4	6.36	51.8
914 x 305 x 253	253.4	918.4	305.5	17.3	27.9	19.1	824.4	5.47	47.7
914 x 305 x 289	289.1	926.6	307.7	19.5	32.0	19.1	824.4	4.81	42.3
914 x 419 x 343	343.3	911.8	418.5	19.4	32.0	24.1	799.6	6.54	41.2
914 x 419 x 388	388.0	921.0	420.5	21.4	36.6	24.1	799.6	5.74	37.4
1016 x 305 x 222	222.0	970.3	300.0	16.0	21.1	30.0	867.8	7.11	54.4
1016 x 305 x 249	249.0	980.2	300.0	16.5	26.0	30.0	868.0	5.77	52.7
1016 x 305 x 272	272.0	990.1	300.0	16.5	31.0	30.0	868.0	4.84	52.7
1016 x 305 x 314	314.0	1000.0	300.0	19.1	35.9	30.0	868.2	4.18	45.6
1016 x 305 x 349	349.0	1008.1	302.0	21.1	40.0	30.0	868.0	3.78	41.2
1016 x 305 x 393	393.0	1016.0	303.0	24.4	43.9	30.0	868.2	3.45	35.7
1016 x 305 x 438	438.0	1025.9	305.4	26.9	49.0	30.0	868.0	3.12	32.3
1016 x 305 x 487	487.0	1036.1	308.5	30.0	54.1	30.0	867.8	2.85	29.0

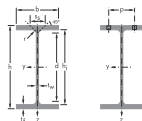

UNIVERSAL BEAMS - DIMENSIONS AND PROPERTIES

To BS 4 : Part 1 : 1993

Second Moment of Area		Radius of Gyration		Elastic Modulus		Plastic Modulus		Buckling Parameter U	Torsional Index x	Wrapping Constant H	Torsional Constant J	Area of Section
Axis x-x	Axis y-y	Axis x-x	Axis y-y	Axis x-x	Axis y-y	Axis x-x	Axis y-y					
cm ⁴	cm ⁴	cm	cm	cm ³	cm ³	cm ³	cm ³			dm ⁴	dm ⁴	dm ²
125900	9308	25.7	7.00	4111	611	4594	937	0.886	32.7	8.17	200	190
153000	11410	25.9	7.07	4935	743	5547	1144	0.886	27.7	10.2	340	228
209500	15840	26.3	7.23	6589	1017	7486	1574	0.886	21.3	14.5	875	303
118000	4383	27.2	5.24	3481	346	3994	542	0.862	43.9	4.80	116	159
136300	5183	27.6	5.39	3987	409	4558	638	0.868	38.7	5.72	169	178
150400	5784	27.8	5.46	4374	455	5000	710	0.871	35.5	6.42	220	194
170300	6630	28.0	5.53	4916	518	5631	811	0.872	31.8	7.42	308	217
150700	4788	29.7	5.30	4018	362	4644	570	0.854	49.8	6.46	119	171
168500	5455	30.0	5.40	4470	411	5156	647	0.858	45.2	7.40	159	187
205300	6850	30.5	5.58	5387	514	6198	807	0.864	38.1	9.39	267	220
240000	8175	30.9	5.71	6234	610	7176	959	0.869	33.2	11.3	404	251
246000	7799	33.1	5.90	5893	535	6808	842	0.856	46.5	13.0	221	224
279200	9066	33.6	6.06	6641	620	7640	974	0.862	41.6	15.2	306	247
339700	11360	34.3	6.27	7985	773	9155	1212	0.870	35.0	19.3	514	289
325300	9423	35.7	6.07	7204	621	8351	982	0.854	46.8	18.4	291	256
376400	11240	36.3	6.27	8269	739	9535	1163	0.861	41.3	22.1	422	286
436300	13300	36.8	6.42	9501	871	10940	1371	0.866	36.2	26.4	626	323
504200	15600	37.0	6.51	10880	1014	12570	1601	0.867	31.9	31.2	926	368
625800	39160	37.8	9.46	13730	1871	15480	2890	0.883	30.1	75.8	1193	437
719600	45440	38.2	9.59	15630	2161	17670	3341	0.885	26.7	88.9	1734	494
406900	9544	38.0	5.81	8387	636	9784	1019	0.849	46.0	21.5	384	282
480300	11750	39.0	6.09	9799	784	11330	1244	0.861	40.1	26.8	575	316
552900	14000	40.0	6.36	11170	934	12800	1469	0.872	35.1	32.2	826	346
643200	16230	40.1	6.37	12860	1082	14830	1712	0.871	30.8	37.7	1253	400
722100	18460	40.3	6.44	14330	1222	16570	1940	0.872	28.0	43.2	1706	445
806600	20490	40.2	6.40	15880	1353	18520	2167	0.868	25.6	48.4	2314	500
908900	23440	40.4	6.49	17720	1535	20740	2467	0.868	23.2	55.9	3166	556
1020400	26720	40.6	6.57	19700	1732	23180	2799	0.867	21.2	64.4	4276	619

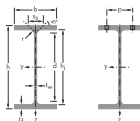

UNIVERSAL COLUMNS - DIMENSIONS AND PROPERTIES

To BS 4 : Part 1 : 1993

Designation	Mass per Metre kg/m	Depth of Section h mm	Width of Section b mm	Thickness Web s mm	Thickness Flange t mm	Root Radius r mm	Depth Between Fillets d mm	Ratios for Local Buckling	
								Flange b/2t	Web d/s
152 x 152 x 23	23.0	152.4	152.2	5.8	6.8	7.6	123.6	11.2	21.3
152 x 152 x 30	30.0	157.6	152.9	6.5	9.4	7.6	123.6	8.13	19.0
152 x 152 x 37	37.0	161.8	154.4	8.0	11.5	7.6	123.6	6.71	15.4
203 x 203 x 46	46.1	203.2	203.6	7.2	11.0	10.2	160.8	9.25	22.3
203 x 203 x 52	52.0	206.2	204.3	7.9	12.5	10.2	160.8	8.17	20.4
203 x 203 x 60	60.0	209.6	205.8	9.4	14.2	10.2	160.8	7.25	17.1
203 x 203 x 71	71.0	215.8	206.4	10.0	17.3	10.2	160.8	5.97	16.1
203 x 203 x 86	86.1	222.2	209.1	12.7	20.5	10.2	160.8	5.10	12.7
254 x 254 x 73	73.1	254.1	254.6	8.6	14.2	12.7	200.3	8.96	23.3
254 x 254 x 89	88.9	260.3	256.3	10.3	17.3	12.7	200.3	7.41	19.4
254 x 254 x 107	107.1	266.7	258.8	12.8	20.5	12.7	200.3	6.31	15.6
254 x 254 x 132	132.0	276.3	261.3	15.3	25.3	12.7	200.3	5.16	13.1
254 x 254 x 167	167.1	289.1	265.2	19.2	31.7	12.7	200.3	4.18	10.4
305 x 305 x 97	96.9	307.9	305.3	9.9	15.4	15.2	246.7	9.91	24.9
305 x 305 x 118	117.9	314.5	307.4	12.0	18.7	15.2	246.7	8.22	20.6
305 x 305 x 137	136.9	320.5	309.2	13.8	21.7	15.2	246.7	7.12	17.9
305 x 305 x 158	158.1	327.1	311.2	15.8	25.0	15.2	246.7	6.22	15.6
305 x 305 x 198	198.1	339.9	314.5	19.1	31.4	15.2	246.7	5.01	12.9
305 x 305 x 240	240.0	352.5	318.4	23.0	37.7	15.2	246.7	4.22	10.7
305 x 305 x 283	282.9	365.3	322.2	26.8	44.1	15.2	246.7	3.65	9.21
356 x 368 x 129	129.0	355.6	368.6	10.4	17.5	15.2	290.2	6.94	17.6
356 x 368 x 153	152.9	362.0	370.5	12.3	20.7	15.2	290.2	7.83	20.2
356 x 368 x 177	177.0	368.2	372.6	14.4	23.8	15.2	290.2	8.95	23.6
356 x 368 x 202	201.9	374.6	374.7	16.5	27.0	15.2	290.2	10.5	27.9
356 x 406 x 235	235.1	381.0	394.8	18.4	30.2	15.2	290.2	6.54	15.8
356 x 406 x 287	287.1	393.6	399.0	22.6	36.5	15.2	290.2	5.47	12.8
356 x 406 x 340	339.9	406.4	403.0	26.6	42.9	15.2	290.2	4.70	10.9
356 x 406 x 393	393.0	419.0	407.0	30.6	49.2	15.2	290.2	4.14	9.48
356 x 406 x 467	467.0	436.6	412.2	35.8	58.0	15.2	290.2	3.55	8.11
356 x 406 x 551	551.0	455.6	418.5	42.1	67.5	15.2	290.2	3.10	6.89
356 x 406 x 634	633.9	474.6	424.0	47.6	77.0	15.2	290.2	2.75	6.10

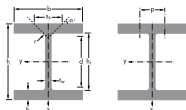
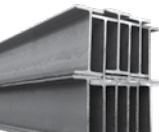

UNIVERSAL COLUMNS - DIMENSIONS AND PROPERTIES

To BS 4 : Part 1 : 1993

Second Moment of Area		Radius of Gyration		Elastic Modulus		Plastic Modulus		Buckling Parameter U	Torsional Index x	Wrapping Constant H	Torsional Constant J	Area of Section
Axis x-x	Axis y-y	Axis x-x	Axis y-y	Axis x-x	Axis y-y	Axis x-x	Axis y-y					
cm ⁴	cm ⁴	cm	cm	cm ³	cm ³	cm ³	cm ³			dm ⁴	dm ⁴	dm ²
1250	400	6.54	3.70	164	52.6	182	80.2	0.840	20.7	0.0212	4.63	29.2
1748	560	6.76	3.83	222	73.3	248	112	0.849	16.0	0.0308	10.5	38.3
2210	706	6.85	3.87	273	91.5	309	140	0.848	13.3	0.0399	19.2	47.1
4568	1548	8.82	5.13	450	152	497	231	0.847	17.7	0.143	22.2	58.7
5259	1778	8.91	5.18	510	174	567	264	0.848	15.8	0.167	31.8	66.3
6125	2065	8.96	5.20	584	201	656	305	0.846	14.1	0.197	47.2	76.4
7618	2537	9.18	5.30	706	246	799	374	0.853	11.9	0.250	80.2	90.4
9449	3127	9.28	5.34	850	299	977	456	0.850	10.2	0.318	137	110
11410	3908	11.1	6.48	898	307	992	465	0.849	17.3	0.562	57.6	93.1
14270	4857	11.2	6.55	1096	379	1224	575	0.850	14.5	0.717	102	113
17510	5928	11.3	6.59	1313	458	1484	697	0.848	12.4	0.898	172	136
22530	7531	11.6	6.69	1631	576	1869	878	0.850	10.3	1.19	319	168
30000	9870	11.9	6.81	2075	744	2424	1137	0.851	8.49	1.63	626	213
22250	7308	13.4	7.69	1445	479	1592	726	0.850	19.3	1.56	91.2	123
27670	9059	13.6	7.77	1760	589	1958	895	0.850	16.2	1.98	161	150
32810	10700	13.7	7.83	2048	692	2297	1053	0.851	14.2	2.39	249	174
38750	12570	13.9	7.90	2369	808	2680	1230	0.851	12.5	2.87	378	201
50900	16300	14.2	8.04	2995	1037	3440	1581	0.854	10.2	3.88	734	252
64200	20310	14.5	8.15	3643	1276	4247	1951	0.854	8.74	5.03	1271	306
78870	24630	14.8	8.27	4318	1529	5105	2342	0.855	7.65	6.35	2034	360
40250	14610	15.6	9.43	2264	793	2479	1199	0.844	19.9	4.18	153	164
48590	17550	15.8	9.49	2684	948	2965	1435	0.844	17.0	5.11	251	195
57120	20530	15.9	9.54	3103	1102	3455	1671	0.844	15.0	6.09	381	226
66260	23690	16.1	9.60	3538	1264	3972	1920	0.844	134	7.16	558	257
79080	30990	16.3	10.2	4151	1570	4687	2383	0.834	12.1	9.54	812	299
99880	38680	16.5	10.3	5075	1939	5812	2949	0.835	10.2	12.30	1441	366
122500	46850	16.8	10.4	6031	2325	6999	3544	0.836	8.85	15.50	2343	433
146600	55370	17.1	10.5	6998	2721	8222	4154	0.837	7.86	18.90	3545	501
183000	67830	17.5	10.7	8383	3291	10000	5034	0.839	6.86	24.30	5809	595
226900	82670	18.0	10.9	9962	3951	12080	6058	0.841	6.05	31.1	9240	702
274800	98130	184	11.0	11580	4629	14240	7108	0.843	5.46	38.8	13720	808

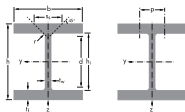

AMERICAN WIDE FLANGE BEAMS
DIMENSIONS ACCORDING TO ASTM A6 / A6M - 03
TOLERANCES : ASTM A6 / A6M - 03, To BS 4 : Part 1 : 1993

Designation	G		Dimensions					A	Dimensions for Detailing				
	lbs/ft	kg/m	h	h	t_w	t_f	r		h ₁	d	Ø	P _{mix}	P _{max}
			mm	mm	mm	mm	mm		mm ²	mm		mm	mm
W 4 x 4	13	19.3	106	103	7.1	8.8	6	24.70	88.4	764	-	-	-
W 5 x 5	16	23.8	127	127	6.1	9.1	8	30.40	108.8	92.8	M12	60	70
W 5 x 5	19	28.1	131	128	6.9	10.9	8	35.90	109.2	932	512	62	70
W 6 x 4	9	13.5	150	100	4.3	5.5	6	17.30	139.0	127.0	-	-	-
W 6 x 4	12	18.0	153	102	5.8	7.1	6	22.90	138.4	126.4	-	-	-
W 6 x 4	16	24.0	160	102	6.6	10.3	6	30.60	139.4	127.4	-	-	-
W 6 x 6	15	22.5	152	152	5.8	6.6	6	28.60	138.8	126.8	516	70	82
W 6 x 6	20	29.8	157	153	6.6	9.3	6	37.90	138.4	126.4	516	72	84
W 6 x 6	25	37.1	162	154	8.1	11.6	6	47.40	138.8	126.8	516	74	84
W 8 x 4	10	156	200	100	4.3	5.2	8	19.10	189.6	173.6	-	-	-
W 8 x 4	13	19.3	203	102	5.8	6.5	8	24.80	190.0	174.0	-	-	-
W 8 x 4	15	22.5	206	102	6.2	8.0	8	28.60	190.0	174.0	-	-	-
W 8 x 5.25	14	216	203	133	5.0	6.4	8	27.08	190.2	174.2	512	62	76
W 8 x 5.25	18	26.6	207	133	5.8	8.4	8	33.90	190.2	174.2	512	62	76
W 8 x 5.25	21	31.3	210	134	6.4	10.2	8	39.70	189.6	173.6	M12	64	75
W 8 x 6.5	24	35.9	201	165	6.2	10.2	10	45.70	180.6	160.6	516	78	96
W 8 x 6.5	28	41.7	205	166	7.2	11.8	10	53.20	181.4	161.4	516	80	96
W 8 x 8	31	46.1	203	203	7.2	11.0	10	58.90	181.0	161.0	M24	94	110
W 8 x 8	35	52.0	206	204	7.9	12.6	10	66.50	180.8	160.8	M24	94	110
W 8 x 8	40	59.0	210	205	9.1	14.2	10	75.50	181.6	161.6	M24	96	112
W 8 x 8	48	71.0	216	206	10.2	17.4	10	91.00	181.2	161.2	M24	98	112
W 8 x 8	58	86.0	222	209	13.0	20.6	10	110.0	180.8	160.8	M24	100	116
W 8 x 8	67	100	229	210	14.5	23.1	10	127.0	181.6	161.6	M24	102	116

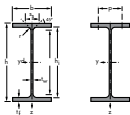
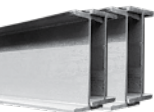

AMERICAN WIDE FLANGE BEAMS
DIMENSIONS ACCORDING TO ASTM A6 / A6M - 03
TOLERANCES : ASTM A6 / A6M - 03, To BS 4 : Part 1 : 1993

Surface		Section Proportion												
A _c	A _c	Strong Axis y - y					Weak Axis z - z					S _y	I _y	I _z
		I _y	W _{el,y}	W _{pl,y}	i _y	A _{c2}	I _z	W _{el,z}	W _{pl,z}	i _z				
		mm ⁴ x10 ⁴	mm ³ x10 ³	mm ³ x10 ³	mm x10	mm ² x10 ²	mm ⁴ x10 ⁴	mm ³ x10 ³	mm ³ x10 ³	mm x10				
0.599	30.90	475.9	89.79	103.3	4.39	8.27	160.6	31.19	47.94	2.55	31.73	6.52	3.79	
0.736	30.95	885.5	139.5	157.2	5.41	9.20	311.0	48.98	74.66	3.20	33.67	8.10	10.80	
0.747	26.46	1099	167.7	190.9	5.53	10.53	381.4	59.60	90.86	3.26	38.03	13.33	13.74	
0.681	50.11	685.5	91.4	102.4	6.29	7.21	91.8	18.36	28.26	2.30	22.35	1.74	4.79	
0.692	37.86	915.9	122.1	138.6	6.33	9.69	125.9	25.37	39.29	2.36	27.47	3.86	6.68	
0.704	29.40	1342	167.8	191.5	6.63	11.43	182.6	35.80	55.24	2.45	34.23	9.35	10.21	
0.890	39.81	1206	158.6	176.1	6.51	9.59	386.6	50.87	77.56	3.68	26.07	4.34	20.42	
0.902	30.33	1714	218.4	243.9	6.73	11.17	555.5	72.62	110.5	3.83	32.23	10.16	30.28	
0.913	24.59	2220	274.1	309.9	6.85	13.93	706.8	91.79	140.0	3.86	38.36	19.51	39.93	
0.778	51.76	1280	128.0	145.2	8.18	9.8	86.89	17.38	27.10	2.13	24.09	1.93	8.22	
0.789	40.34	1662	163.7	188.1	8.17	13.06	115.4	22.63	35.69	2.15	28.21	3.99	11.10	
0.794	35.25	2004	194.5	222.8	8.36	14.14	142.0	27.85	43.72	2.22	31.59	5.97	13.87	
0.914	43.00	1980	195.1	217.7	8.55	11.40	251.3	37.78	58.03	3.05	27.17	3.74	24.25	
0.921	34.49	2587	250.0	279.8	8.72	13.49	329.8	49.60	76.17	3.11	32.01	7.35	32.48	
0.930	29.66	3139	298.9	335.3	8.87	14.87	409.6	61.13	93.76	3.20	36.12	12.04	40.82	
1.03	28.75	3438	342.1	379.4	8.67	14.77	764.3	92.64	141.1	4.09	38.34	14.56	69.50	
1.04	24.97	4088	398.8	445.6	8.77	17.21	900.5	108.5	165.5	4.12	42.56	22.39	83.95	
1.19	25.78	4545	447.8	495.6	8.81	16.96	1535	151.2	229.5	5.12	40.96	22.27	141.3	
1.20	22.89	5268	511.5	569.0	8.90	18.60	1784	174.9	265.5	5.18	44.79	32.41	166.7	
1.20	20.28	6113	582.2	652.9	8.99	21.59	2040	199.1	302.8	5.19	49.26	46.86	195.4	
1.22	17.07	7658	709.0	802.8	9.18	24.52	2537	246.3	374.5	5.28	56.68	82.02	250.0	
1.24	14.28	9467	852.9	980.5	9.26	31.06	3138	300.3	458.2	5.33	65.87	140.8	317.8	
1.25	12.59	11325	989.1	1149	9.45	35.33	3663	348.9	532.9	5.38	73.60	211.3	385.5	

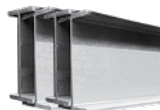
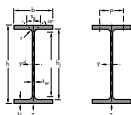

AMERICAN WIDE FLANGE BEAMS
DIMENSIONS ACCORDING TO ASTM A6 / A6M - 03
TOLERANCES : ASTM A6 / A6M - 03

Designation	G		Dimensions					A	Dimensions for Detailing				
	lbs/ft	kg/m	h	h	t_w	t_f	r		h ₁	d	Ø	P _{mix}	P _{max}
			mm	mm	mm	mm	mm		mm	mm		mm	mm
W 10 x 4	12	17.9	251	101	4.8	5.3	8	22.80	240.4	224.4	-	-	-
W 10 x 4	15	22.3	254	102	5.8	6.9	8	28.50	240.2	224.2	-	-	-
W 10 x 4	17	25.3	257	102	6.1	8.4	8	32.20	240.2	224.2	-	-	-
W 10 x 4	19	28.4	260	102	6.4	10.0	8	36.30	240.0	224.0	-	-	-
W 10 x 5.75	16	24.0	253	145	5.0	6.4	8	31.12	240.2	224.2	M16	72	76
W 10 x 5.75	22	32.7	258	146	6.1	9.1	8	41.90	239.8	223.8	M16	72	76
W 10 x 5.75	26	38.5	262	147	6.6	11.2	8	49.10	239.6	223.6	M16	74	78
W 10 x 5.75	30	44.8	266	148	7.6	13.0	8	57.00	240.0	224.0	M16	74	78
W 10 x 8	33	49.1	247	202	7.4	11.0	13	62.60	225.0	199.0	M27	90	112
W 10 x 8	39	58.0	252	203	8.0	13.5	13	74.20	225.0	199.0	M27	90	113
W 10 x 8	45	67.0	257	204	8.9	15.7	13	85.80	225.6	199.6	M27	90	114
W 10 x 10	49	73.0	253	254	8.6	14.2	13	92.90	224.6	198.6	M27	102	148
W 10 x 10	54	80.0	256	255	9.4	15.6	13	102.0	224.8	198.8	M27	102	150
W 10 x 10	60	89.0	260	256	10.7	17.3	13	114.0	225.4	199.4	M27	104	150
W 10 x 10	68	101	264	257	11.9	19.6	13	129.0	224.8	198.8	M27	106	152
W 10 x 10	77	115	269	259	13.5	22.1	13	146.0	224.8	198.8	M27	106	154
W 10 x 10	88	131	275	261	15.4	25.1	13	167.0	224.8	198.8	M27	108	156
W 10 x 10	100	149	282	263	17.3	28.4	13	190.0	225.2	199.2	M27	110	158
W 10 x 10	112	167	289	265	19.2	31.8	13	212.0	225.4	199.4	M27	112	160
W 12 x 4	14	21.0	303	101	5.1	5.7	8	26.80	291.6	275.6	-	-	-
W 12 x 4	16	23.8	305	101	5.6	6.7	8	30.40	291.6	275.6	-	-	-
W 12 x 4	19	28.3	309	102	6.0	8.9	8	35.90	291.2	275.2	-	-	-
W 12 x 4	22	32.7	313	102	6.6	10.8	8	41.80	291.4	275.4	-	-	-
W 12 x 6.5	21	31.0	306	164	5.0	7.4	8	39.38	291.2	275.2	M20	78	82
W 12 x 6.5	26	38.7	310	165	5.8	9.7	8	49.40	290.6	274.6	M20	80	84
W 12 x 6.5	30	44.5	313	166	6.6	11.2	8	56.70	290.6	274.6	M20	80	84
W 12 x 6.5	35	52.0	317	167	7.6	13.2	8	66.50	290.6	274.6	M20	82	86

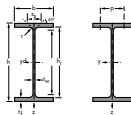
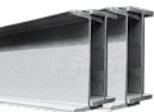

AMERICAN WIDE FLANGE BEAMS

DIMENSIONS ACCORDING TO ASTM A6 / A6M - 03

TOLERANCES : ASTM A6 / A6M - 03

Surface		Section Proportion											
A _c	A _c	Strong Axis y - y					Weak Axis z - z						
		I _y	W _{eI_y}	W _{pI_y}	I _y	A _{c2}	I _z	W _{eI_z}	W _{pI_z}	I _z	S _z	I _t	I _w
m ² /m	m ² /t	mm ⁴	mm ³	mm ³	mm	mm ²	mm ⁴	mm ³	mm ³	mm	mm	mm ⁴	mm ⁴
		x10 ⁴	x10 ³	x10 ³	x10	x10 ²	x10 ⁴	x10 ³	x10 ³	x10		x10 ⁴	x10 ⁵
0.883	49.17	2252	179.5	207.8	9.92	13.26	91.34	18.09	28.67	2.00	24.80	2.50	13.74
0.891	39.59	2901	228.4	264.6	10.6	16.08	122.6	24.03	38.20	2.07	29.01	4.68	18.63
0.896	35.30	3430	266.9	307.5	10.30	17.06	149.2	29.25	46.20	2.15	32.27	6.77	22.95
0.902	31.74	3998	307.5	352.9	10.51	18.02	177.5	34.81	54.71	2.21	35.72	9.80	27.64
1.06	43.48	3477	274.8	307.5	10.57	13.90	325.6	44.90	69.02	3.23	27.17	4.16	49.44
1.07	32.77	4895	379.4	424.9	10.83	17.19	472.6	64.74	99.48	3.36	33.67	10.05	73.10
1.09	28.04	6014	459.1	514.1	11.05	18.89	593.7	80.77	123.90	3.47	38.37	17.03	93.24
1.10	24.34	7118	535.2	603	11.14	21.91	703.5	95.06	146.20	3.50	42.99	26.45	112.40
1.26	25.76	7069	572.4	633.9	10.63	21.77	1513	149.8	228.50	4.92	44.63	24.53	210.40
1.28	21.92	8736	693.4	770.8	10.85	24.04	1884	185.6	282.80	5.04	50.23	41.11	267.70
1.29	19.20	10360	806.6	902	11.00	27.01	2224	218.0	332.20	5.10	55.53	62.61	323.40
1.48	20.31	11290	892.1	986.1	11.02	25.78	3880	305.5	463.30	6.46	52.27	57.94	552.90
1.49	18.59	12570	982.4	1091	11.10	28.10	4314	338.3	513.30	6.50	55.83	76.15	622.90
1.50	16.75	14260	1097	1226	11.18	31.84	4841	3782	574.50	6.51	60.50	104.40	712.40
1.51	14.91	16380	1241	1398	11.27	35.73	5549	431.9	656.60	6.56	66.37	150.30	828.0
1.52	13.29	18940	1408	1599	11.38	40.43	6405	494.6	752.80	6.62	72.89	215.30	975.30
1.54	11.75	22150	1611	1847	11.52	46.39	7446	570.6	869.70	6.68	80.80	315.90	1161.0
1.56	10.47	25940	1840	2129	11.69	52.63	8622	655.7	1001.00	6.74	89.30	456.50	1384.0
1.58	9.42	30020	2078	2427	11.87	59.05	9879	745.6	1139.00	6.81	98.01	639.30	1631.0
0.986	46.74	3708	244.8	287.1	11.75	16.56	98.31	19.47	31.19	1.91	25.85	3.17	21.63
0.989	41.47	4280	280.7	328.6	11.87	18.30	115.6	22.89	36.70	1.95	28.36	4.50	25.59
1.00	35.31	5431	351.5	406.9	12.27	19.89	158.1	30.99	49.15	2.09	33.14	7.72	35.44
1.01	30.68	6507	415.8	480.9	12.47	22.22	191.9	37.62	59.63	2.14	37.57	12.36	43.61
1.24	40.25	6554	428.4	476.3	12.90	16.66	544.4	66.39	101.6	3.72	29.17	6.25	121.3
1.25	32.27	8527	550.1	611.8	13.12	19.64	726.8	88.10	134.8	3.83	34.61	12.76	163.7
1.26	28.27	9934	634.8	708.3	13.21	22.26	854.7	103.0	157.8	3.88	38.37	19.30	194.4
1.27	24.28	11851	747.7	838.5	13.32	25.81	1026	122.9	188.6	3.92	43.39	31.10	236.4

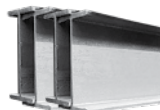
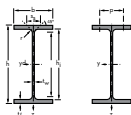

AMERICAN WIDE FLANGE BEAMS
DIMENSIONS ACCORDING TO ASTM A6 / A6M - 03
TOLERANCES : ASTM A6 / A6M - 03

Designation	G		Dimensions					A	Dimensions for Detailing					
	lbs/ft	kg/m	h	h	t _w	t _i	r		h _i	d	Ø	P _{mix}	P _{max}	
			mm	mm	mm	mm	mm		mm	mm		mm	mm	mm
W 12 x 8	40	60	303	203	7.5	13.1	15	76.10	276.8	246.8	M27	90	113	
W 12 x 8	45	67	306	204	8.5	14.6	15	65.20	276.8	246.8	M27	90	114	
W 12 x 8	50	74	310	205	9.4	16.3	15	94.80	277.4	247.4	M27	90	115	
W 12 x 10	53	79	306	254	8.8	14.6	15	101.0	276.8	246.8	M27	90	164	
W 12 x 10	58	86	310	254	9.1	16.3	15	110.0	277.4	247.4	M27	90	164	
W 12 x 12	65	97	308	305	9.9	15.4	15	123.0	277.2	247.2	M27	102	200	
W 12 x 12	72	107	311	306	10.9	17.0	15	136.0	277.0	247.0	M27	104	200	
W 12 x 12	79	117	314	307	11.9	18.7	15	1500	276.6	246.6	M27	106	202	
W 12 x 12	87	129	318	308	13.1	20.6	15	165.0	276.8	246.8	M27	106	202	
W 12 x 12	96	143	323	309	14.0	22.9	15	182.0	277.2	247.2	M27	108	204	
W 12 x 12	106	158	327	310	15.5	25.1	15	201.0	276.8	246.8	M27	108	204	
W 12 x 12	120	179	333	313	18.0	28.1	15	228.0	276.8	246.8	M27	112	208	
W 12 x 12	136	202	341	315	20.1	31.8	15	257.0	277.4	247.4	M27	114	210	
W 12 x 12	152	226	348	317	22.1	35.6	15	288.0	276.8	246.8	M27	116	212	
W 12 x 12	170	253	356	319	24.4	39.6	15	323.0	276.8	246.8	M27	118	214	
W 12 x 12	190	283	365	322	26.9	44.1	15	360.0	276.8	246.8	M27	120	216	
W 12 x 12	210	313	374	325	30.0	48.3	15	399.0	277.4	247.4	M27	124	220	
W 12 x 12	230	342	382	328	32.6	52.6	15	437.0	276.8	246.8	M27	126	222	
W 14 x 5	22	32.9	349	127	5.8	8.5	10	41.90	332.0	312.0	M12	62	70	
W 14 x 5	26	39.0	353	128	6.5	10.7	10	49.60	331.6	311.6	M12	64	70	
W 14 x 6.75	30	44.6	352	171	6.9	9.8	10	57.10	332.4	312.4	M22	82	84	
W 14 x 6.75	34	51.0	355	171	7.2	11.6	10	64.50	331.8	311.8	M22	84	84	
W 14 x 6.75	38	58.0	358	172	7.9	13.1	10	72.30	331.8	311.8	M22	84	84	
W 14 x 8	43	64.0	347	203	7.7	13.5	15	81.30	320.0	290.0	M27	90	113	
W 14 x 8	48	72.0	350	204	8.6	15.1	15	50.00	319.8	289.8	M27	90	114	
W 14 x 8	53	79.0	354	205	9.4	16.8	15	101.00	320.4	290.4	M27	90	115	

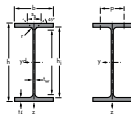
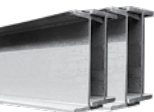

AMERICAN WIDE FLANGE BEAMS

DIMENSIONS ACCORDING TO ASTM A6 / A6M - 03

TOLERANCES : ASTM A6 / A6M - 03

Surface		Section Proportion											
A _c	A _c	Strong Axis y - y					Weak Axis z - z						
		I _y	W _{eI_y}	W _{pI_y}	I _y	A _z	I _z	W _{eI_z}	W _{pI_z}	I _z	S _z	I _t	I _w
		mm ⁴ x10 ⁴	mm ³ x10 ³	mm ³ x10 ³	mm ⁴ x10	mm ² x10 ²	mm ⁴ x10 ⁴	mm ³ x10 ³	mm ³ x10 ³	mm ⁴ x10	mm	mm	mm ⁴ x10 ⁴
1.38	23.12	12860	848.9	940.7	13.02	27.60	1829	180.2	275.2	4.91	51.27	39.15	383.7
1.39	20.75	14510	948.4	1057	13.06	31.08	2069	202.8	310.3	4.93	55.27	54.03	438.5
1.40	18.74	16450	1061	1188	13.17	34.43	2344	228.7	350.2	4.97	59.57	74.05	504.7
1.58	20.09	17670	1155	1275	13.26	31.95	3990	314.2	477.8	6.30	55.57	65.49	846.5
1.59	18.44	19850	1280	1417	1343	33.55	4455	350.8	533.1	6.36	59.27	86.96	960.0
1.79	18.5	22240	1444	1591	13.43	35.52	7286	477.8	724.7	7.69	58.27	91.50	1559.0
1.80	16.83	24790	1594	1765	13.49	39.08	8123	530.9	805.8	7.72	62.47	122.1	1754.0
1.81	15.38	27510	1753	1949	13.56	42.68	9024	587.9	892.8	7.76	66.87	161.1	1966.0
1.82	14.01	30770	1935	2164	13.65	47.07	10040	651.9	990.9	7.80	71.87	214.5	2218.0
1.83	12.78	34760	2153	2419	13.81	50.82	11270	7294	1109	7.86	77.37	288.3	2535.0
1.84	11.68	38630	2363	2672	13.88	56.26	12470	804.8	1225	7.89	83.27	380.3	2840.0
1.86	10.39	44530	2675	3053	13.99	65.24	14380	918.7	1401	7.95	91.77	543.7	3338.0
1.88	9.26	51982	3049	3510	14.19	73.62	16588	1053	1608	8.02	101.3	782.7	3959.0
1.89	8.35	59560	3423	3975	14.36	81.65	18930	1194	1825	8.10	110.9	1089	4611.0
1.91	7.57	68230	3833	4490	14.55	91.01	21460	1346	2059	8.16	121.2	1495	5362.0
1.94	6.85	78680	4311	5098	14.78	101.5	24590	1527	2340	8.26	132.7	2062	6317.0
1.96	6.26	89560	4789	5716	14.98	114.1	27700	1705	2617	8.33	144.2	2742	7329.0
1.99	5.78	100510	5262	6334	15.16	125.1	31020	1892	2907	8.42	155.4	3552	8392.0
1.18	35.96	8258	473.2	541.5	14.07	22.31	291.0	45.82	71.8	2.64	34.52	8.65	84.11
1.19	30.38	10231	579.7	661.5	14.33	25.25	375.0	58.6	91.6	2.74	39.62	15.04	109.6
1.36	30.24	12140	690.1	777.0	14.57	26.29	817.9	95.66	147.7	3.78	38.18	16.10	239.1
1.36	26.88	14130	796.3	894.5	14.80	28.04	968.1	113.2	174.4	3.87	42.16	23.92	285.0
1.37	24.21	16040	896.2	1009	14.91	30.73	1113	1294	199.5	3.93	45.82	33.46	330.4
1.46	22.93	17830	1027	1141	14.80	31.66	1885	185.7	284.3	4.81	52.27	43.21	523.4
1.47	20.61	20100	1149	1282	14.86	35.26	2140	209.8	321.6	4.85	56.37	59.71	599.1
1.48	18.72	22650	1280	1433	14.98	38.67	2416	235.7	361.6	4.89	60.57	80.7	685.7

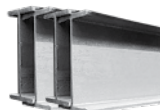
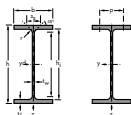

AMERICAN WIDE FLANGE BEAMS
DIMENSIONS ACCORDING TO ASTM A6 / A6M - 03
TOLERANCES : ASTM A6 / A6M - 03

Designation	G		Dimensions					A	Dimensions for Detailing					
	lbs/ft	kg/m	h	h	t _w	t _v	r		h ₁	d	Ø	P _{max}	P _{max}	
			mm	mm	mm	mm	mm		mm	mm		mm	mm	mm
									mm ²					
						×10 ²								
W 14 x 10	61	91	353	254	9.5	16.4	15	115.0	320.2	290.2	M27	90.0	164	
W 14 x 10	68	101	357	255	10.5	18.3	15	129.0	320.4	290.4	M27	90.5	165	
W 14 x 10	74	110	360	256	11.4	19.9	15	141.0	320.2	290.2	M27	91.4	166	
W 14 x 10	82	122	363	257	13.0	21.7	15	155.0	319.6	289.6	M27	93.0	167	
W 14 x 14.5	90	134	356	369	11.2	18.0	95	171.0	320.0	290.0	M27	100	264	
W 14 x 14.5	99	147	360	370	12.3	19.8	15	188.0	320.4	290.4	M27	100	264	
W 14 x 14.5	109	162	364	371	13.3	21.8	15	206.0	320.4	290.4	M27	102	266	
W 14 x 14.5	120	179	368	373	15.0	23.9	15	228.0	320.2	290.2	M27	104	268	
W 14 x 14.5	132	196	372	374	16.4	26.2	15	250.0	319.6	289.6	M27	104	268	
W 14 x 16	145	216	375	394	17.3	27.7	15	275.0	319.6	289.6	M27	106	288	
W 14 x 16	159	237	380	395	18.9	30.2	15	301.0	319.6	289.6	M27	108	290	
W 14 x 16	176	262	387	398	21.1	33.3	15	334.0	320.4	290.4	M27	110	292	
W 14 x 16	193	287	393	399	22.6	36.6	15	366.0	319.8	289.8	M27	112	294	
W 14 x 16	211	314	399	401	24.9	39.6	15	400.0	319.8	289.8	M27	114	296	
W 14 x 16	233	347	407	404	27.2	43.7	15	442.0	319.6	289.6	M27	116	298	
W 14 x 16	257	382	416	406	29.8	48.0	15	488.0	320.0	290.0	M27	118	300	
W 14 x 16	283	421	425	409	32.8	52.6	15	537.0	319.8	289.8	M27	122	304	
W 14 x 16	311	463	435	412	35.8	57.4	15	590.0	320.2	290.2	M27	124	306	
W 14 x 16	342	509	446	416	39.1	62.7	15	652.0	320.6	290.6	M27	128	310	
W 14 x 16	370	551	455	418	42.0	67.6	15	703.0	319.8	289.8	M27	132	312	
W 14 x 16	398	592	465	421	45.0	72.3	15	755.0	320.4	290.4	M27	134	316	
W 14 x 16	426	634	474	424	47.6	77.1	15	806.0	319.8	289.8	M27	140	312	
W 14 x 16	455	677	483	428	51.2	81.5	15	865.0	320.0	290.0	M27	144	316	
W 14 x 16	500	744	498	432	55.6	88.9	15	948.0	320.2	290.2	M27	148	320	
W 14 x 16	550	818	514	437	60.5	97.0	15	1050.0	320.0	290.0	M27	154	326	
W 14 x 16	605	900	531	442	65.9	106.0	15	1150.0	319.0	289.0	M27	158	330	
W 14 x 16	665	990	550	448	71.9	115.0	15	1260.0	320.0	290.0	M27	164	336	
W 14 x 16	730	1086	569	454	78.0	125.0	15	1390.0	319.0	289.0	M27	170	342	

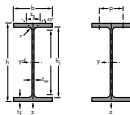
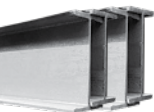

AMERICAN WIDE FLANGE BEAMS

DIMENSIONS ACCORDING TO ASTM A6 / A6M - 03

TOLERANCES : ASTM A6 / A6M - 03

Surface		Section Proportion											
A _c	A _c	Strong Axis y - y					Weak Axis z - z						
		I _y	W _{eI_y}	W _{pI_y}	I _y	A _z	I _z	W _{eI_z}	W _{pI_z}	I _z	S _z	I _t	I _w
m ² /m	m ² /t	mm ⁴	mm ³	mm ³	mm	mm ²	mm ⁴	mm ³	mm ³	mm	mm	mm ⁴	mm ⁴
		x10 ⁴	x10 ³	x10 ³	x10	x10 ²	x10 ⁴	x10 ³	x10 ³	x10		x10 ⁴	x10 ⁵
1.68	18.47	26690	1512	1676	15.19	38.83	4483	353.0	537.8	6.23	59.87	91.18	1269
1.69	16.67	30150	1689	1880	15.29	42.98	5062	397.0	605.5	6.27	64.67	125.3	1450
1.70	15.39	33090	1838	2055	15.36	46.67	5570	435.2	664.2	6.30	68.77	160.3	1609
1.71	13.99	36530	2013	2266	15.35	52.81	6147	478.4	732.0	6.30	73.97	211.8	1788
2.14	15.98	41510	2332	2562	15.60	45.19	15080	817.3	1237	9.40	64.77	168.8	4305
2.15	14.58	46290	2572	2838	15.70	49.72	16720	903.9	1369	9.43	69.47	223.7	4836
2.16	13.34	51540	2832	3139	15.81	53.98	18560	1001	1516	9.49	74.47	295.5	5432
2.17	12.12	57440	3122	3482	15.86	60.72	20680	1109	1683	9.52	80.37	393.8	6119
2.18	11.10	63630	3421	3837	15.94	66.50	22860	1222	1856	9.56	86.37	517.1	6829
2.27	10.48	71140	3794	4262	16.07	70.32	28250	1434	2176	10.13	90.27	637.3	8515
2.28	9.64	78780	4146	4686	16.18	77.10	31040	1572	2387	10.16	96.87	825.5	9489
2.30	8.75	89410	4620	5260	16.35	86.55	35020	1760	2676	10.23	105.3	1116	10940
2.31	8.04	99710	5074	5813	16.50	93.46	38780	1944	2957	10.29	113.4	1464	12300
2.33	7.42	110200	5525	6374	16.62	103.3	42600	2125	3236	10.33	121.7	1870	13740
2.35	6.77	124900	6140	7139	16.81	113.9	48090	2380	3629	10.43	132.2	2510	15850
2.37	6.20	141300	6794	7965	17.03	126.0	53620	2641	4031	10.49	143.4	3326	18130
2.39	5.68	159600	7510	8880	17.24	139.9	60080	2938	4489	10.58	155.6	4398	20800
2.42	5.23	180200	8283	9878	17.48	154.3	67040	3254	4978	10.66	168.2	5735	23850
2.45	4.81	204500	9172	11030	17.75	170.6	75400	3625	5552	10.78	182.1	7513	27630
2.47	4.49	226100	9939	12050	17.95	184.9	82490	3947	6051	10.85	194.8	9410	30870
2.50	4.22	250200	10760	13140	18.20	200.3	90170	4284	6574	10.93	207.2	11560	34670
2.52	3.98	274200	11570	14220	18.42	214.0	98250	4634	7117	11.03	219.4	14020	38570
2.55	3.76	299500	12400	15350	18.62	231.9	106900	4994	7680	11.13	231.8	16790	42920
2.59	3.48	342100	13740	17170	19.00	256.1	119900	5552	8549	11.25	251.0	21840	49980
2.63	3.21	392200	15260	19260	19.39	283.3	135500	6203	9561	11.40	272.1	28510	58650
2.67	2.96	450200	16960	21620	19.79	313.8	153300	6938	10710	11.55	295.5	37350	68890
2.72	2.75	518900	18870	24280	20.27	349.2	173400	7739	11960	11.72	319.5	48210	81530
2.77	2.55	595700	20940	27210	20.73	385.8	196200	8645	13380	11.90	345.6	62290	96080

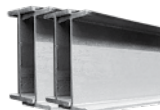
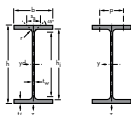

AMERICAN WIDE FLANGE BEAMS
DIMENSIONS ACCORDING TO ASTM A6 / A6M - 03
TOLERANCES : ASTM A6 / A6M - 03

Designation	G		Dimensions					A	Dimensions for Detailing					
	lbs/ft	kg/m	h	h	t_w	t_f	r		h ₁	d	Ø	Pmix	Pmax	
			mm	mm	mm	mm	mm		mm	mm		mm	mm	mm
									$\times 10^2$					
W 16 x 5.5	26	38.8	399	140	6.4	8.8	10	49.50	381.4	361.4	M12	68	82	
W 16 x 5.5	31	46.1	403	140	7.0	11.2	10	58.80	380.6	360.6	M12	68	82	
W 16 x 7	36	53.0	403	177	7.5	10.9	10	68.40	381.2	361.2	M22	86	90	
W 16 x 7	40	60.0	407	178	7.7	12.8	10	76.10	381.4	361.4	M22	86	90	
W 16 x 7	45	67.0	410	179	8.8	14.4	10	85.80	381.2	361.2	M22	86	92	
W 16 x 7	50	75.0	413	180	9.7	16.0	10	94.80	381.0	361.0	M22	88	92	
W 16 x 7	57	85.0	417	181	10.9	18.2	10	108.0	380.6	360.6	M22	90	94	
W 16 x 10.25	67	100.0	415	260	10.0	16.9	10	127.0	381.2	361.2	M27	90	170	
W 16 x 10.25	77	114.0	420	261	11.6	19.3	10	146.0	381.4	361.4	M27	91.6	171	
W 16 x 10.25	89	132.0	425	263	13.3	22.2	10	169.0	380.6	360.6	M27	91.3	173	
W 16 x 10.25	100	149.0	431	265	14.9	25.0	10	190.0	381.0	361.0	M27	94.9	175	
W 18 x 6	35	52.0	450	152	7.6	10.8	10	66.50	428.4	408.4	M16	76	82	
W 18 x 6	40	60.0	455	153	8.0	13.3	10	76.10	428.4	408.4	M16	76	84	
W 18 x 6	46	68.0	459	154	9.1	15.4	10	87.10	428.2	408.2	M16	78	84	
W 18 x 7.5	41	61.0	450	189	8.1	10.8	10	76.40	428.4	408.4	M24	92	96	
W 18 x 7.5	45	67.0	454	190	8.5	12.7	10	85.50	428.6	408.6	M24	92	96	
W 18 x 7.5	50	74.0	457	190	9.0	14.5	10	94.80	428.0	408.0	M24	92	96	
W 18 x 7.5	55	82.0	460	191	9.9	16.0	10	105.0	428.0	408.0	M24	92	98	
W 18 x 7.5	60	89.0	463	192	10.5	17.7	10	114.0	427.6	407.6	M24	94	98	
W 18 x 7.5	65	97.0	466	193	11.4	19.0	10	123.0	427.8	407.8	M24	94	100	
W 18 x 7.5	71	106.0	469	194	12.6	20.6	10	134.0	427.8	407.8	M24	96	100	

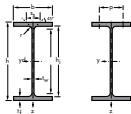
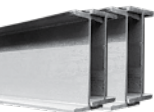

AMERICAN WIDE FLANGE BEAMS

DIMENSIONS ACCORDING TO ASTM A6 / A6M - 03

TOLERANCES : ASTM A6 / A6M - 03

Surface		Section Proportion											
A _c	A _c	Strong Axis y - y					Weak Axis z - z						
		I _y	W _{eI_y}	W _{pI_y}	i _y	A _z	I _z	W _{eI_z}	W _{pI_z}	i _z	S _z	I _t	I _w
m ² /m	m ² /t	mm ⁴	mm ³	mm ³	mm	mm ²	mm ⁴	mm ³	mm ³	mm	mm	mm ⁴	mm ⁴
		x10 ⁴	x10 ³	x10 ³	x10	x10 ²	x10 ⁴	x10 ³	x10 ³	x10		x10 ⁴	x10 ⁵
1.33	34.03	12620	632.6	727.8	15.93	27.4	403.5	57.65	90.55	2.85	35.67	11.17	153.2
1.33	28.91	15550	771.9	883.6	16.26	30.49	513.6	73.37	114.9	2.95	41.11	19.25	196.6
1.48	27.76	18600	922.9	1045	16.54	32.41	1009	114.0	176.6	3.85	41.01	2275	387.2
1.49	25.10	21570	1060	1194	16.87	33.77	1205	135.4	209.0	3.99	45.02	32.81	467.4
1.50	22.29	24530	1196	1354	16.91	38.39	1379	154.1	238.6	4.01	49.28	46.9	538.5
1.51	20.19	27460	1330	1510	16.98	42.37	1559	173.2	268.7	4.05	53.37	63.79	612.8
1.52	17.87	31530	1512	1725	17.06	48.05	1803	199.3	310.1	4.08	59.04	93.24	715.2
1.83	18.41	39760	1916	2129	17.70	44.05	4954	381.1	581.4	6.25	55.52	99.70	1961
1.84	16.10	46140	2197	2456	17.79	51.2	5725	438.7	670.9	6.27	61.92	149.4	2296
1.86	14.07	53830	2533	2850	17.89	58.87	6739	512.5	785.4	6.33	69.42	227.1	2730
1.88	12.56	61840	2870	3247	18.04	66.35	7765	586.1	899.8	6.39	76.62	324.1	3195
1.48	28.37	21200	942.0	1088	17.89	36.4	634.0	83.43	131.5	3.09	40.92	21.24	304.8
1.49	25.01	25480	1120	1284	18.33	38.85	796.1	104.1	163.1	3.24	46.32	33.58	387.2
1.50	21.88	29680	1293	1487	18.44	44.31	940.5	122.1	192.1	3.28	51.62	51.07	461.2
1.62	27.06	25380	1128	1286	18.23	38.59	1217.5	128.8	200.5	3.99	41.42	26.02	586.0
1.63	24.33	29470	1298	1473	18.56	40.91	1454.4	153.1	237.5	4.12	45.62	37.46	706.8
1.64	22.08	33260	1456	1650	18.75	43.67	1661	174.8	271.0	4.19	49.74	52.03	811.4
1.65	20.10	37000	1608	1829	18.83	48.06	1862	195.0	303.0	4.22	53.63	69.55	915.7
1.66	18.52	40960	1769	2013	18.96	51.33	2093	218.0	338.8	4.29	57.66	91.36	1035
1.66	17.17	44680	1917	2189	19.02	55.76	2282	237.8	370.4	4.31	61.35	113.9	1137
1.67	15.83	48790	2081	2385	19.04	61.34	2515	259.2	405.3	4.32	65.49	146.6	1260

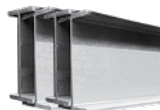
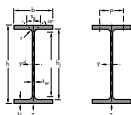

AMERICAN WIDE FLANGE BEAMS
DIMENSIONS ACCORDING TO ASTM A6 / A6M - 03
TOLERANCES : ASTM A6 / A6M - 03

Designation	G		Dimensions					A	Dimensions for Detailing					
	lbs/ft	kg/m	h	h	t _w	t _v	r		h ₁	d	Ø	P _{max}	P _{max}	
			mm	mm	mm	mm	mm		mm	mm		mm	mm	mm
									mm ²					
						×10 ²								
W 18 x 11	76	113	463	280	10.8	17.3	10	144.0	428.4	408.4	M27	90.0	174	
W 18 x 11	86	128	467	282	12.2	19.6	10	163.0	427.8	407.8	M27	90.0	176	
W 18 x 11	97	144	472	283	13.6	22.1	10	184.0	427.8	407.8	M27	92.0	178	
W 18 x 11	106	158	476	284	15.0	23.9	10	201.0	428.2	408.2	M27	94.0	178	
W 18 x 11	119	177	482	286	16.6	26.9	10	226.0	428.2	408.2	M27	94.0	180	
W 18 x 11	130	193	489	283	17.0	30.5	10	247.0	428.0	408..	M27	97.0	193	
W 18 x 11	143	213	495	285	18.5	33.5	10	271.0	428.0	408.0	M27	98.5	195	
W 18 x 11	158	235	501	287	20.6	36.6	10	299.0	427.8	407.8	M27	100.6	197	
W 18 x 11	175	260	509	289	22.6	40.4	10	331.0	428.2	408.2	M27	102.6	199	
W 21 x 6.5	44	66.0	525	165	8.9	11.4	13	83.90	502.2	476.2	M22	88.9	93	
W 21 x 6.5	50	74.0	529	166	9.7	13.6	13	94.80	501.8	475.8	M22	89.7	94	
W 21 x 6.5	57	85.0	535	166	10.3	16.5	13	108.0	502.0	476.0	M22	90.3	94	
W 21 x 8.25	62	92.0	533	209	10.2	15.6	13	118.0	501.8	475.8	M27	94.0	104	
W 21 x 8.25	68	101	537	210	10.9	17.4	13	129.0	502.2	476.2	M27	94.0	104	
W 21 x 8.25	73	109	539	211	11.6	18.8	13	139.0	501.4	475.4	M27	96.0	106	
W 21 x 8.25	83	123	544	212	13.1	21.2	13	157.0	501.6	475.6	M27	96.0	106	
W 21 x 8.25	93	138	549	214	14.7	23.6	13	176.0	501.8	475.8	M27	98.0	108	
W 21 x 12.25	101	150	543	312	12.7	20.3	13	192.0	502.4	476.4	M27	92.7	222	
W 21 x 12.25	111	165	546	313	14.0	22.2	13	211.0	501.6	475.6	M27	94.0	223	
W 21 x 12.25	122	182	551	315	15.2	24.4	13	232.0	502.2	476.2	M27	95.2	225	
W 21 x 12.25	132	196	554	316	16.5	26.3	13	250.0	501.4	475.4	M27	96.5	226	
W 21 x 12.25	147	219	560	318	18.3	29.2	13	279.0	501.6	475.6	M27	98.3	228	
W 21 x 12.25	166	248	571	315	19.0	34.5	13	315.0	502.0	476.0	M27	99.0	225	
W 21 x 12.25	182	272	577	318	21.1	37.6	13	346.0	501.8	475.8	M27	101.1	228	
W 21 x 12.25	201	300	585	319	23.1	41.4	13	382.0	502.2	476.2	M27	103.1	229	
W 24 x 7	55	82.0	599	178	10.0	12.8	13	105.0	573.4	547.4	M24	90.0	100	
W 24 x 7	62	92.0	603	179	10.9	15	13	117.0	573.0	547.0	M24	90.9	101	

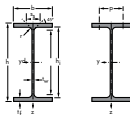
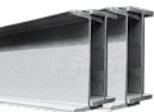

AMERICAN WIDE FLANGE BEAMS
DIMENSIONS ACCORDING TO ASTM A6 / A6M - 03
TOLERANCES : ASTM A6 / A6M - 03

Surface		Section Proportion												
A _c	A _c	Strong Axis y - y						Weak Axis z - z				S _x	I _x	I _y
		I _y	W _{eI_y}	W _{pI_y}	I _y	A _z	I _z	W _{eI_z}	W _{pI_z}	I _z				
m ² /m	m ² /t	mm ⁴	mm ³	mm ³	mm	mm ²	mm ⁴	mm ³	mm ³	mm	mm	mm ⁴	mm ⁴	
		x10 ⁴	x10 ³	x10 ³	x10	x10 ²	x10 ⁴	x10 ³	x10 ³	x10		x10 ⁴	x10 ⁵	
2.01	17.76	55600	2402	2673	19.65	52.45	6335	452.5	691.3	6.63	57.12	118.8	3143	
2.02	15.74	63690	2728	3049	19.73	59.32	7333	520.1	795.9	6.70	63.11	172.6	3666	
2.03	14.06	72600	3076	3454	19.86	66.42	8358	590.7	905.5	6.74	69.51	245.5	4224	
2.04	12.95	79620	3346	3774	19.91	73.41	9137	643.5	988.7	6.75	74.51	314.1	4662	
2.06	11.60	91040	3777	4282	20.07	81.97	10510	743.7	1131	6.82	82.16	445.2	5431	
2.06	10.65	102400	4186	4754	20.39	84.90	11540	815.5	1253	6.85	89.72	607.3	6055	
2.08	9.76	114300	4619	5272	20.54	92.94	12950	908.7	1398	6.91	97.22	803.3	6882	
2.09	8.90	127300	5083	5839	20.63	103.80	14450	1007	1554	6.95	105.5	1059	7775	
2.11	8.12	143700	5646	6525	20.83	114.8	16300	1128	1743	7.01	115.1	1423	8922	
1.67	25.40	35100	1337	1563	20.47	50.13	857.3	103.9	166.2	3.20	46.93	33.29	562.9	
1.68	22.47	41100	1554	1810	20.77	54.98	1042	125.5	200.3	3.31	52.13	49.2	688.6	
1.69	19.96	48580	1816	2105	21.22	59.15	1264	152.2	241.8	3.42	58.23	74.55	845.5	
1.86	20.13	55240	2073	2362	21.67	58.07	2379	227.7	354.8	4.50	56.59	76.96	1589	
1.87	18.41	61760	2300	2623	21.85	62.72	2692	256.4	399.9	4.56	60.95	102.9	1813	
1.88	17.23	66730	2476	2826	21.93	66.47	2951	279.7	436.5	4.61	64.39	127.4	1991	
1.89	15.32	76100	2798	3208	22.02	75.34	3377	318.6	499.2	4.64	70.71	182.3	2300	
1.90	13.74	86160	3139	3617	22.10	84.98	3870	361.7	569.1	4.68	77.16	254.0	2660	
2.28	15.18	100900	3716	4148	22.93	73.11	10290	659.3	1010	7.32	68.53	218.2	7019	
2.29	13.87	111000	4066	4556	22.95	80.55	11360	725.8	1113	7.34	73.63	286.2	7782	
2.30	12.71	123600	4486	5042	23.10	87.84	12730	808.1	1241	7.41	79.23	377.6	8812	
2.31	11.79	134000	4839	5459	23.14	95.36	13850	876.7	1349	7.44	84.33	474.6	9629	
2.33	10.65	151100	5396	6116	23.27	106.2	15680	986.0	1520	7.50	91.93	649.7	11020	
2.34	9.49	177500	6219	7063	23.77	112.4	18000	1143	1759	7.57	103.2	985.6	12930	
2.36	8.68	197300	6840	7814	23.87	125.0	20190	1270	1959	7.63	111.5	1293	14660	
2.38	7.94	220800	7548	8672	24.05	137.8	22450	1408	2176	7.67	121.1	1718	16550	
1.87	22.80	56030	1871	2199	23.17	63.40	1209	135.8	218.3	3.40	50.83	50.58	1034	
1.88	20.34	64680	2145	2515	23.45	69.44	1441	161.0	258.5	3.50	56.13	72.81	1239	

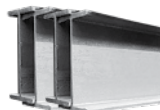
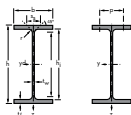

AMERICAN WIDE FLANGE BEAMS
DIMENSIONS ACCORDING TO ASTM A6 / A6M - 03
TOLERANCES : ASTM A6 / A6M - 03

Designation	G		Dimensions					A	Dimensions for Detailing					
	lbs/ft	kg/m	h	h	t _w	t _v	r		h _i	d	Ø	P _{mix}	P _{max}	
			mm	mm	mm	mm	mm		mm	mm		mm	mm	mm
									×10 ²					
W 24 x 9	68	101	603	228	10.5	14.9	13	130.0	573.2	547.2	M27	94	122	
W 24 x 9	76	113	608	228	11.2	17.3	13	145.0	573.4	547.4	M27	94	122	
W 24 x 9	84	125	612	229	11.9	19.6	13	159.0	572.8	546.8	M27	96	124	
W 24 x 9	94	140	617	230	13.1	22.2	13	179.0	572.6	546.6	M27	96	124	
W 24 x 9	103	153	623	229	14	24.9	13	196.0	573.2	547.2	M27	94	139	
W 24 x 12.75	104	155	611	324	12.7	19.0	13	197.0	573.0	547.0	M27	96	218	
W 24 x 12.75	117	174	616	325	14	21.6	13	222.0	572.8	546.8	M27	98	220	
W 24 x 12.75	131	195	622	327	15.4	24.4	13	248.0	573.2	547.2	M27	98	222	
W 24 x 12.75	146	217	628	328	16.5	27.7	13	277.0	572.6	546.6	M27	100	222	
W 24 x 12.75	162	241	635	329	17.1	31.0	13	308.0	573.0	547.0	M27	100	224	
W 24 x 12.75	176	262	641	327	19	34.0	13	333.0	573.0	547.0	M27	102	222	
W 24 x 12.75	192	285	647	329	20.6	37.1	13	361.0	572.8	546.8	M27	104	224	
W 24 x 12.75	229	341	661	333	24.4	43.9	13	434.0	573.2	547.2	M27	108	228	
W 24 x 12.75	279	415	679	338	29.5	53.1	13	529.0	572.8	546.8	M27	114	232	
W 24 x 12.75	306	455	689	340	32	57.9	13	579.0	573.2	547.2	M27	116	234	
W 24 x 12.75	335	498	699	343	35.1	63.0	13	635.0	573.0	547.0	M27	120	238	
W 24 x 12.75	370	551	711	347	38.6	69.1	13	702.0	572.8	546.8	M27	122	242	
W 27 x 10	84	125	678	253	11.7	16.3	15	160.0	645.4	615.4	M27	100	148	
W 27 x 10	94	140	684	254	12.4	18.9	15	179.0	646.2	616.2	M27	100	148	
W 27 x 10	102	152	688	254	13.1	21.1	15	194.0	645.8	615.8	M27	102	148	
W 27 x 10	114	170	693	256	14.5	23.6	15	216.0	645.8	615.8	M27	102	150	
W 27 x 10	129	192	702	254	15.5	27.9	15	244.0	646.2	616.2	M27	104	148	
W 30 x 10.5	99	147	753	265	13.2	17.0	17	188.0	719.0	685.0	M27	106	160	
W 30 x 10.5	108	161	758	266	13.8	19.3	17	205.0	719.4	685.4	M27	106	160	
W 30 x 10.5	116	173	762	267	14.4	21.6	17	221.0	718.8	684.8	M27	106	162	
W 30 x 10.5	124	185	766	267	14.9	23.6	17	235.0	718.8	684.8	M27	106	162	
W 30 x 10.5	132	196	770	268	15.6	25.4	17	251.0	719.2	685.2	M27	108	162	
W 30 x 10.5	148	220	779	266	16.5	30.0	17	281.0	719.0	685.0	M27	108	160	

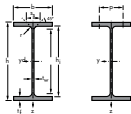
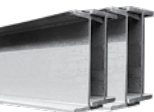

AMERICAN WIDE FLANGE BEAMS DIMENSIONS ACCORDING TO ASTM A6 / A6M - 03 TOLERANCES : ASTM A6 / A6M - 03

Surface		Section Proportion											
A ₁	A ₂	Strong Axis y - y					Weak Axis z - z				S _x	I _x	I _y
		I _y	W _{el,y}	W _{pl,y}	i _y	A _z	I _z	W _{el,z}	W _{pl,z}	i _z			
m ² /m	m ² /t	mm ⁴	mm ³	mm ³	mm	mm ²	mm ⁴	mm ³	mm ³	mm	mm	mm ⁴	mm ⁴
		x10 ⁴	x10 ³	x10 ³	x10	x10 ²	x10 ⁴	x10 ³	x10 ³	x10		x10 ⁴	x10 ³
2.07	20.36	76470	2536	2905	24.27	67.31	2950	258.8	404.4	4.77	55.57	79.88	2545
2.08	18.37	87570	2881	3290	24.62	71.99	3425	300.5	468.8	4.87	61.01	113.3	2981
2.09	16.71	98650	3224	3679	24.86	77.28	3932	343.4	535.6	4.96	66.37	156.0	3442
2.11	15.03	111990	3630	4150	25.05	85.02	4514	392.5	613.1	5.03	72.71	220.0	3982
2.12	13.74	125200	4019	4602	25.29	91.66	4998	436.5	682.4	5.05	79.03	297.5	4457
2.47	15.95	129000	4222	4728	25.57	81.57	10780	666.0	1022	7.39	65.93	197.7	9437
2.48	14.24	147200	4778	5362	25.74	90.28	12370	761.0	1170	7.46	72.43	283.2	10920
2.50	12.77	167900	5398	6074	25.95	99.83	14240	871.0	1340	7.56	79.43	400.9	12700
2.51	11.53	190800	6076	6848	26.21	107.7	16310	995.0	1531	7.67	87.13	564.6	14680
2.53	10.62	214200	6746	7605	26.57	112.8	18430	1120	1721	7.79	94.33	758.6	16780
2.53	9.69	235990	7363	8349	26.63	125.6	19850	1214	1871	7.72	102.2	998.1	18250
2.55	8.92	260700	8059	9175	26.78	136.7	22060	1341	2071	7.79	110.0	1295	20480
2.58	7.59	318300	9630	11070	27.09	163.4	27090	1627	2522	7.90	127.4	2153	25720
2.63	6.33	399800	11780	13690	27.48	199.9	34300	2030	3160	8.05	150.9	3824	33470
2.65	5.84	444520	12903	15093	27.72	218.5	38090	2241	3496	8.11	163.0	4948	37770
2.68	5.37	494700	14150	16670	27.92	241.1	42580	2483	3885	8.19	176.3	6420	42850
2.71	4.92	557510	15682	18599	28.18	267.2	48400	2790	4377	8.30	192.0	8525	49570
2.32	18.47	116480	3495	4009	27.22	84.24	4410	348.6	545.5	5.25	61.87	119.4	4816
2.33	16.69	136070	3979	4549	27.64	90.07	5174	407.4	636.4	5.39	67.77	168.4	5709
2.34	15.39	150600	4378	5002	27.88	95.63	5777	454.9	710.3	5.46	72.87	221.4	6408
2.36	13.86	169930	4904	5618	28.02	106.1	6618	517.0	809.3	5.53	79.27	306.7	7393
2.36	12.35	197900	5639	6457	28.49	114.8	7643	601.8	941.0	5.60	88.87	463.2	8657
2.51	17.06	166100	4411	5110	29.76	105.4	5289	399.2	630.8	5.31	67.12	161.5	7141
2.52	15.72	186060	4909	5666	30.17	111.0	6070	456.6	719.7	5.45	72.32	211.7	8259
2.53	14.58	205800	5402	6218	30.49	116.4	6873	514.9	809.9	5.57	77.52	273.6	9391
2.54	13.74	223000	5821	6691	30.76	121.1	7510	562.5	883.9	5.65	82.02	336.7	10320
2.55	12.96	240300	6241	7174	30.95	127.3	8175	610.1	958.8	5.71	86.32	408.9	11290
2.56	11.62	278200	7143	8198	31.48	136.3	9440	709.9	1113	5.80	96.42	609.0	13200

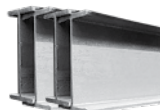
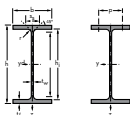

AMERICAN WIDE FLANGE BEAMS
DIMENSIONS ACCORDING TO ASTM A6 / A6M - 03
TOLERANCES : ASTM A6 / A6M - 03

Designation	G		Dimensions					A	Dimensions for Detailing					
	lbs/ft	kg/m	h	h	t _w	t _i	r		h _i	d	Ø	P _{mix}	P _{max}	
			mm	mm	mm	mm	mm		mm	mm		mm	mm	mm
									mm ²					
						×10 ²								
W 33 x 11.05	118	176	835	292	14	18.8	18	224.0	797.4	761.4	M27	108	186	
W 33 x 11.05	130	193	840	292	14.7	21.7	18	247.0	796.6	760.6	M27	108	186	
W 33 x 11.05	141	210	846	293	15.4	24.4	18	268.0	797.2	761.2	M27	110	188	
W 33 x 11.05	152	226	851	294	16.1	26.8	18	288.0	797.4	761.4	M27	110	188	
W 33 x 11.05	169	251	859	292	17.0	31.0	18	319.0	797	761.0	M27	112	186	
W 36 x 12	135	201	903	304	15.2	20.1	19	256.0	862.8	824.8	M27	112	198	
W 36 x 12	150	223	911	304	15.9	23.9	19	285.0	863.2	825.2	M27	112	198	
W 36 x 12	160	238	915	305	16.5	25.9	19	303.0	863.2	825.2	M27	112	200	
W 36 x 12	170	253	919	306	17.3	27.9	19	323.0	863.2	825.2	M27	114	200	
W 36 x 12	182	271	923	307	18.4	30.0	19	346.0	863	825	M27	114	202	
W 36 x 12	194	289	927	308	19.4	32.0	19	368.0	863	825	M27	116	202	
W 36 x 12	210	313	932	309	21.1	34.5	19	399.0	863	825	M27	118	204	
W 36 x 16.5	230	342	912	418	19.3	32.0	24	436.0	848	800	M27	126	312	
W 36 x 16.5	245	365	916	419	20.3	34.3	24	465.0	847.4	799.4	M27	128	314	
W 36 x 16.5	260	387	921	420	21.3	36.6	24	494.0	847.8	799.8	M27	128	314	
W 36 x 16.5	280	417	928	422	22.5	39.9	24	532.0	848.2	800.2	M27	130	316	
W 36 x 16.5	300	446	933	423	24	42.7	24	570.0	847.6	799.6	M27	130	318	
W 36 x 16.5	328	488	942	422	25.9	47.0	24	622.0	848	800	M27	132	316	
W 36 x 16.5	359	534	950	425	28.4	51.1	24	680.0	847.8	799.8	M27	136	320	
W 36 x 16.5	393	585	960	427	31.0	55.9	24	716.0	848.2	800.2	M27	138	322	
WV 36 x 16.5	439	653	972	431	34.5	62.0	24	832.0	848	800	M27	144	320	
W 36 x 16.5	527	784	996	437	40.9	73.9	24	998.0	848.2	800.2	M27	152	326	
W 36 x 16.5	650	967	1028	446	50	89.9	24	1232	848.2	800.2	M27	160	334	

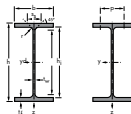
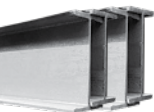

AMERICAN WIDE FLANGE BEAMS

DIMENSIONS ACCORDING TO ASTM A6 / A6M - 03

TOLERANCES : ASTM A6 / A6M - 03

Surface		Section Proportion											
A _c	A _c	Strong Axis y - y					Weak Axis z - z						
		I _y	W _{eI_y}	W _{pI_y}	i _y	A _z	I _z	W _{eI_z}	W _{pI_z}	i _z	S _z	I _t	I _w
m ² /m	m ² /t	mm ⁴	mm ³	mm ³	mm	mm ²	mm ⁴	mm ³	mm ³	mm	mm	mm ⁴	mm ⁴
		x10 ⁴	x10 ³	x10 ³	x10	x10 ²	x10 ⁴	x10 ³	x10 ³	x10		x10 ⁴	x10 ⁵
2.78	15.79	246400	5901	6816	33.15	123.8	7823	535.8	843.6	5.91	72.69	226.9	12990
2.79	14.40	278400	6630	7627	33.60	130.9	9029	618.5	971.3	6.05	79.19	309.9	15070
2.80	13.29	310700	7346	8430	34.02	138.1	10260	700.2	1098	6.18	85.29	409.0	17260
2.81	12.42	340100	7992	9163	34.32	145.1	11380	774.3	1213	6.28	90.79	517.5	19280
2.82	11.25	386500	8999	10304	34.79	154.7	12900	883.6	1383	6.36	100.1	737.6	22050
2.96	14.70	325200	7203	8356	35.61	144.9	9442	621.2	982.3	6.07	77.66	298.0	18340
2.97	13.26	376800	8273	9540	36.32	1532	11220	738.5	1163	6.27	85.96	426.8	22020
2.98	12.53	406400	8883	10229	36.59	159.6	12290	805.6	1267	6.36	90.56	518.8	24200
2.99	11.80	437500	9520	10963	36.79	167.9	13370	873.6	1375	6.43	95.36	630.9	26450
3.00	11.06	471600	10218	11783	36.91	178.8	14520	945.8	1491	6.48	100.7	775.0	28840
3.01	10.45	504500	10884	12566	37.04	188.9	15640	1016	1603	6.52	105.7	929.8	31210
3.03	9.67	548200	11765	13629	37.10	205.6	17040	1103	1748	6.54	112.4	1171	34160
3.42	9.98	624900	13700	15450	37.85	190.1	39010	1867	2882	9.46	111.4	1193	75410
3.43	9.40	670500	14640	16520	38.00	200.4	42120	2011	3106	9.52	117.0	1446	81730
3.44	8.88	718300	15600	17630	38.17	210.9	45280	2156	3332	9.58	122.6	1734	88370
3.46	8.27	787600	16970	19210	38.46	223.9	50070	2373	3668	9.70	130.4	2200	98540
3.47	7.76	846800	18150	20600	38.56	239.1	53980	2552	3951	9.73	137.5	2685	106740
3.48	7.13	935390	19860	22615	38.80	259.3	59010	2797	4336	9.75	148.0	3514	117890
3.50	6.56	1031000	21710	24830	38.94	284.8	65560	3085	4796	9.82	158.7	4542	132070
3.52	6.02	1143090	23814	27363	39.16	312.0	72770	3408	5310	9.88	170.9	5932	148220
3.56	5.45	1292000	26590	30730	39.41	348.7	83050	3854	6022	9.99	186.6	8124	171280
3.62	4.62	1593000	31980	37340	39.95	417.6	103300	4728	7424	10.18	216.8	13730	218490
3.70	3.83	2033000	39540	46810	40.64	517.1	133900	6003	9486	10.43	257.9	24930	292450

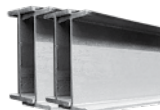
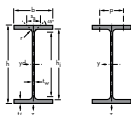

AMERICAN WIDE FLANGE BEAMS
DIMENSIONS ACCORDING TO ASTM A6 / A6M - 03
TOLERANCES : ASTM A6 / A6M - 03

Designation	G		Dimensions					A	Dimensions for Detailing					
	lbs/ft	kg/m	h	h	t _w	t _f	r		h ₁	d	Ø	Pmix	Pmax	
			mm	mm	mm	mm	mm		mm	mm		mm	mm	mm
									mm ²					
						×10 ²								
W 40 x 12	149	222	970	300	16	21.1	30	282	928	868	M27	134	194	
W 40 x 12	167	249	980	300	16.5	26	30	317	928	868	M27	134	194	
W 40 x 12	183	272	990	300	16.5	31	30	346	928	868	M27	134	194	
W 40 x 12	211	314	1000	300	19.1	35.9	30	400	928	868	M27	136	194	
W 40 x 12	235	350	1008	302	21.1	40	30	446	928	868	M27	140	196	
W 40 x 12	264	393	1016	303	24.4	43.9	30	501	928	868	M27	142	198	
W 40 x 12	278	415	1020	304	26	46	30	528	928	868	M27	144	198	
W 40 x 12	294	438	1026	305	27	49	30	556	928	868	M27	137	215	
W 40 x 12	331	494	1036	309	31	54	30	629	928	868	M27	148	204	
W 40 x 12	392	584	1056	314	36	64	30	744	928	868	M27	154	208	
W 40 x 16	199	296	982	400	16.5	27.1	30	377	928	868	M27	134	294	
W 40 x 16	215	321	990	400	16.5	31	30	408	928	868	M27	134	294	
W 40 x 16	249	371	1000	400	19	36.1	30	473	928	868	M27	136	294	
W 40 x 16	277	412	1008	402	21.1	40	30	525	928	868	M27	140	296	
W 40 x 16	297	443	1012	402	23.6	41.9	30	564	928.2	868.2	M27	142	296	
W 40 x 16	324	483	1020	404	25.4	46	30	615	928	868	M27	144	298	
W 40 x 16	362	539	1030	407	28.4	51.1	30	687	927.8	867.2	M27	146	302	
W 40 x 16	372	554	1032	408	29.5	52	30	706	928	868	M27	150	296	
W 40 x 16	397	591	1040	409	31	55.9	30	753	928.2	868.2	M27	148	304	
W 40 x 16	431	642	1048	412	34	60	30	818	928	868	M27	154	300	
W 40 x 16	503	748	1068	417	39	70	30	953	928	868	M27	160	306	
W 40 x 16	593	883	1092	424	45.5	82	30	1125	928	868	M27	166	312	
W 44 x 16	230	343	1090	400	18	31	20	436	1028	988	M27	116	294	
W 44 x 16	262	390	1100	400	20	36	20	497	1028	988	M27	118	294	
W 44 x 16	290	433	1108	402	22	40	20	551	1028	988	M27	120	296	
W 44 x 16	335	499	1118	405	26	45	20	635	1028	988	M27	124	300	

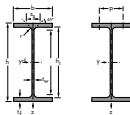
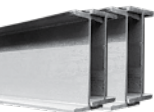

AMERICAN WIDE FLANGE BEAMS

DIMENSIONS ACCORDING TO ASTM A6 / A6M - 03

TOLERANCES : ASTM A6 / A6M - 03

Surface		Section Proportion												
A _c	A _c	Strong Axis y - y					Weak Axis z - z					S _x	I _x	I _y
		I _y	W _{eI_y}	W _{pI_y}	I _y	A _z	I _z	W _{eI_z}	W _{pI_z}	I _z	S _y			
m ² /m	m ² /t	mm ⁴ x10 ⁴	mm ³ x10 ²	mm ³ x10 ³	mm x10	mm ² x10 ²	mm ⁴ x10 ⁴	mm ³ x10 ³	mm ³ x10 ³	mm x10	mm	mm ⁴ x10 ⁴	mm ⁴ x10 ⁸	
3.06	13.77	407700	8405	9803	37.97	172.2	9546	636	1020	5.81	93.35	406	21370	
3.08	12.37	481100	9818	11350	38.97	180.7	11750	784	1245	6.09	103.6	584.4	26620	
3.10	11.37	553800	11190	12820	39.96	184.6	14000	934	1470	6.35	113.6	822.4	32070	
3.11	9.90	644200	12880	14850	40.11	213.4	16230	1082	1713	6.37	126.0	1252	37540	
3.13	8.96	723000	14350	16590	40.30	236.0	18460	1223	1941	6.44	136.2	1701	43020	
3.14	8.01	807700	15900	18540	40.18	271.3	20500	1353	2168	6.40	147.3	2332	48080	
3.15	7.60	853100	16728	19571	40.17	288.6	21710	1428	2298	6.41	153.1	2713	51080	
3.17	7.24	909800	17740	20770	40.41	300.9	23360	1532	2464	6.47	160.1	3200	55290	
3.19	6.47	1028000	19845	23413	40.42	344.5	26820	1736	2818	6.53	174.1	4433	64010	
3.24	5.56	1246100	23600	28039	40.93	403.2	33430	2130	3475	6.70	199.1	7230	81240	
3.48	11.76	618700	12600	14220	40.52	181.5	28850	1443	2235	8.75	105.6	762.6	65900	
3.50	10.89	696400	14070	15800	41.27	184.6	33120	1656	2555	9.00	113.6	1021	76030	
3.51	9.47	812100	16240	18330	41.48	212.5	38480	1924	2976	9.03	126.1	1575	89440	
3.53	8.58	909800	18050	20440	41.66	235.0	43410	2160	3348	9.10	136.1	2134	101460	
3.53	7.99	966510	19101	21777	41.41	261.8	45500	2264	3529	8.98	142.5	2545	106740	
3.55	7.36	1067480	20931	23923	41.66	282.7	50710	2510	3919	9.08	152.5	3311	119900	
3.58	6.64	1202540	23350	26824	41.83	316.4	57630	2832	4436	9.16	165.7	4546	137550	
3.59	6.47	1232000	23880	27500	41.79	328.0	59100	2897	4547	9.15	168.6	4860	141330	
3.60	6.10	1331040	25597	29530	42.05	346.3	64010	3130	4916	9.22	177.9	5927	154330	
3.62	5.65	1450590	27683	32097	42.12	379.6	70280	3412	5379	9.27	189.1	7440	170670	
3.67	4.91	1731940	32433	37881	42.62	438.9	85110	4082	6459	9.45	214.1	11670	210650	
3.74	4.23	2096420	38396	45265	43.16	516.5	104970	4952	7874	9.66	244.6	18750	265670	
3.71	10.83	867400	15920	18060	44.58	206.5	33120	1656	2568	8.71	103.4	1037	92710	
3.73	9.55	1005000	18280	20780	44.98	230.6	38480	1924	2988	8.80	115.4	1564	108680	
3.75	8.66	1126000	20320	23160	45.19	254.4	43410	2160	3362	8.87	125.4	2130	123500	
3.77	7.56	1294000	23150	26600	45.14	300.4	49980	2468	3870	8.87	139.4	3135	143410	

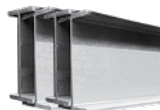
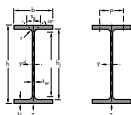

EUROPEAN SPECIFICATION BEAMS WITH PARALLEL FLANGES IN ACCORDANCE WITH EURONORM 53-62

Designation	Weight per Metre G	Depth of Section h	Depth of Section b	Thickness of Web t_w	Thickness of Web t_f	Radius of the Roof Fillet r	Area of Section A	Inner Depth Between Flanges h_i	Depth of Straight Portion of Web h_s
	kg/m	mm	mm	mm	mm	mm	cm ²	mm	mm
HE 100 AA	12.2	91	100	4.2	5.5	12	15.6	80	56
HE 100 A	16.7	96	100	5.0	8.0	12	21.2	80	56
HE 100 B	20.4	100	100	6.0	10.0	12	26.0	80	56
HE 120 AA	14.6	109	120	4.2	5.5	12	18.6	98	74
HE 120 A	19.9	114	120	5.0	8.0	12	25.3	98	74
HE 120 B	26.7	120	120	6.5	11.0	12	34.0	98	74
HE 140 AA	18.1	128	140	4.3	6.0	12	23.0	116	92
HE 140 A	24.7	133	140	5.5	8.5	12	31.4	116	92
HE 140 B	33.7	140	140	7.0	12.0	12	43.0	116	92
HE 160 AA	23.8	148	160	4.5	7.0	15	30.4	134	104
HE 160 A	30.4	152	160	6.0	9.0	15	38.8	134	104
HE 160 B	42.6	160	160	8.0	13.0	15	54.3	134	104
HE 160 M	76.2	180	166	14.0	23.0	15	97.1	134	104
HE 180 AA	28.7	167	180	5.0	7.5	15	36.5	152	122
HE 180 A	35.5	171	180	6.0	9.5	15	45.3	152	122
HE 180 B	51.2	180	180	8.5	14.0	15	65.3	152	122
HE 180 M	88.9	200	186	14.5	24.0	15	113	152	122
HE 200 AA	34.6	186	200	5.5	8.0	18	44.1	170	134
HE 200 A	42.3	190	200	6.5	10.0	18	53.8	170	134
HE 200 B	61.3	200	200	9.0	15.0	18	78.1	170	134
HE 200 M	103	220	206	15.0	25.0	18	131	170	134
HE 220 AA	40.4	205	220	6.0	8.5	18	51.5	188	152
HE 220 A	50.5	210	220	7.0	11.0	18	64.3	188	152
HE 220 B	71.5	220	220	9.5	16.0	18	91.0	188	152
HE 220 M	117	240	226	15.5	26.0	18	149	188	152
HE 240 M	47.4	224	240	6.5	9.0	21	60.4	206	164
HE 240 A	60.3	230	240	7.5	12.0	21	76.8	206	164
HE 240 I3	83.2	240	240	10.0	17.0	21	106	206	164
HE 240 M	157	270	248	18.0	32.0	21	200	206	164
HE 260 AA	54.1	244	260	6.5	9.5	24	69.0	225	177
HE 260 A	68.2	250	260	7.5	12.5	24	86.8	225	177
HE 260 B	93.0	260	260	10.0	17.5	24	118	225	177
HE 260 M	172	290	268	18.0	32.5	24	220	225	177

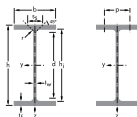

EUROPEAN SPECIFICATION BEAMS WITH PARALLEL FLANGES IN ACCORDANCE WITH EURONORM 53-62

Moment of Inertia		Radius of Modulus		Elastic Sectional Modulus		Plastic Section Modulus		Warping Constant	Torsional Constant
I_y	I_z	r_y	r_z	W_y	W_z	W_{ply}	W_{plz}	I_w	I_t
cm ⁴	cm ⁴	cm	cm	cm ³	cm ³	cm ³	cm ³	dm ⁴	cm ⁴
237	92.1	3.89	2.43	52.0	18.4	58.4	28.4	0.002	2.33
349	134	4.06	2.51	72.8	26.8	83.0	41.1	0.003	5.28
450	167	4.16	2.53	89.9	33.5	104	51.4	0.003	9.33
413	159	4.72	2.93	75.8	26.5	84.1	40.6	0.004	2.59
606	231	4.89	3.02	106	38.5	119	58.9	0.006	6.04
864	318	5.04	3.06	144	52.9	165	81.0	0.009	13.9
719	275	5.59	3.45	112	39.3	124	59.9	0.010	3.43
1033	389	5.73	3.52	155	55.6	173	84.8	0.015	8.10
1509	550	5.93	3.58	216	78.5	245	120	0.023	20.2
1283	479	6.50	3.97	173	59.8	190	91.4	0.024	6.43
1673	616	6.57	3.98	220	76.9	245	118	0.031	12.1
2492	889	6.78	4.05	312	111	345	170	0.048	31.3
5098	1759	7.25	4.26	566	212	675	325	0.108	161
1967	730	7.34	4.47	236	81.1	258	124	0.046	8.31
2510	925	7.45	4.52	294	103	325	156	0.060	14.9
3831	1363	7.66	4.57	426	151	481	231	0.094	42.2
7483	2580	8.13	4.77	748	277	883	425	0.200	201
2944	1068	8.17	4.92	317	107	347	163	0.085	12.5
3692	1336	8.28	4.98	389	134	429	204	0.108	21.0
5696	2003	8.54	5.07	570	200	643	306	0.171	59.7
10640	3651	9.00	5.27	967	354	1135	543	0.347	258
4170	1510	9.00	5.42	407	137	445	209	0.146	15.5
5410	1955	9.17	5.51	515	178	568	271	0.194	28.6
8091	2843	9.43	5.59	736	258	827	394	0.296	77.0
14600	5012	9.89	5.79	1217	444	1419	679	0.574	313
5835	2077	9.83	5.87	521	173	571	264	0.240	22.1
7763	2769	10.1	6.00	675	231	745	352	0.329	42.1
11260	3923	10.3	6.08	938	327	1053	498	0.488	104
24290	8158	11.0	6.39	1799	657	2117	1006	1.15	626
7981	2788	10.8	6.36	654	214	714	328	0.383	30.1
10450	3668	11.0	6.50	836	282	920	430	0.517	54.2
14920	5135	11.2	6.58	1148	395	1283	602	0.755	127
31310	10450	11.9	6.90	2159	780	2524	1192	1.73	720

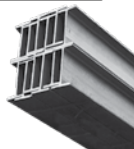
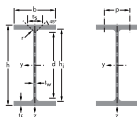

EUROPEAN SPECIFICATION BEAMS WITH PARALLEL FLANGES IN ACCORDANCE WITH EURONORM 53-62

Designation	Weight per Metre G	Depth of Section h	Depth of Section b	Thickness of Web t_w	Thickness of Web t_c	Radius of the Roof Fillet r	Area of Section A	Inner Depth Between Flanges h_i	Depth of Straight Portion of Web h_s
	kg/m	mm	mm	mm	mm	mm	cm ²	mm	mm
HE 280 AA	61.2	264	280	7.0	10.0	24	78	244	196
HE 280 A	76.4	270	280	8.0	13.0	24	97.3	244	196
HE 280 B	103	280	280	10.5	18.0	24	131	244	196
HE 280 M	189	310	288	18.5	33.0	24	240	244	196
HE 300 AA	69.8	283	300	7.5	10.5	27	88.9	262	208
HE 300 A	88.3	290	300	8.5	14.0	27	113	262	208
HE 300 B	117	300	300	11.0	19.0	27	149	262	208
HE 300 C	177	320	305	16.0	29.0	27	225	262	208
HE 300 M	238	340	310	21.0	39.0	27	303	262	208
HE 320 AA	74.2	301	300	8.0	11.0	27	94.6	279	225
HE 320 A	97.6	310	300	9.0	15.5	27	124	279	225
HE 320 B	127	320	300	11.5	20.5	27	161	279	225
HE 320 M	245	359	309	21.0	40.0	27	312	279	225
HE 340 AA	78.9	320	300	8.5	11.5	27	101	297	243
HE 340 A	105	330	300	9.5	16.5	27	133	297	243
HE 340 B	134	340	300	12.0	21.5	27	171	297	243
HE 340 M	248	377	309	21.0	40.0	27	316	297	243
HE 360 AA	83.7	339	300	9.0	12.0	27	107	315	261
HE 360 A	112	350	300	10.0	17.5	27	143	315	261
HE 360 B	142	360	300	12.5	22.5	27	181	315	261
HE 360 M	250	395	308	21.0	40.0	27	319	315	261
HE 400 AA	92.4	378	300	9.5	13.0	27	118	352	298
HE 400 x 107	107	384	297	10.0	16.0	27	136	352	298
HE 400 A	125	390	300	11.0	19.0	27	159	352	298
HE 400 B	155	400	300	13.5	24.0	27	198	352	298
HE 400 M	256	432	307	21.0	40.0	27	326	352	298
HE 450 AA	100	425	300	10.0	13.5	27	127	398	344
HE 450 x 123	123	435	300	10.2	18.5	27	158	398	344
HE 450 A	140	440	300	11.5	21.0	27	178	398	344
HE 450 B	171	450	300	14.0	26.0	27	218	398	344
HE 450 M	263	478	307	21.0	40.0	27	335	398	344
HE 500 AA	107	472	300	10.5	14.0	27	137	444	390
HE 500 A	155	490	300	12.0	23.0	27	198	444	390
HE 500 B	187	500	300	14.5	28.0	27	239	444	390
HE 500 M	270	524	306	21.0	40.0	27	344	444	390

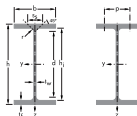

EUROPEAN SPECIFICATION BEAMS WITH PARALLEL FLANGES IN ACCORDANCE WITH EURONORM 53-62

Moment of Inertia		Radius of Modulus		Elastic Sectional Modulus		Plastic Section Modulus		Warping Constant	Torsional Constant
I_y	I_z	i_y	i_z	W_y	W_z	W_{ply}	W_{plz}	I_w	I_t
cm ⁴	cm ⁴	cm	cm	cm ³	cm ³	cm ³	cm ³	dm ⁴	cm ⁴
10560	3664	11.6	6.85	800	262	873	399	0.591	35.5
13670	4763	11.9	7.00	1013	340	1112	518	0.786	63.5
19270	6595	12.1	7.09	1376	471	1534	718	1.13	146
39550	13160	12.8	7.40	2551	914	2966	1397	2.52	807
13800	4734	12.5	7.30	976	316	1065	482	0.879	47.8
18260	6310	12.7	7.49	1260	421	1383	641	1.20	87.8
25170	8563	13.0	7.58	1678	571	1869	870	1.69	189
40950	13740	13.5	7.80	2559	901	2927	1374	2.91	604
59200	19400	14.0	8.00	3482	1252	4078	1913	4.39	1411
16450	4959	13.2	7.24	1093	331	1196	506	1.04	53.6
22930	6985	13.6	7.49	1479	466	1628	710	1.51	112
30820	9239	13.8	7.57	1926	616	2149	939	2.07	230
68130	19710	14.8	7.95	3796	1276	4435	1951	5.01	1506
19550	5185	13.9	7.18	1222	346	1341	529	1.23	60.0
27690	7436	14.4	7.46	1678	496	1850	756	1.83	131
36660	9690	14.6	7.53	2156	646	2408	986	2.46	263
76370	19710	15.6	7.90	4052	1276	4718	1953	5.60	1512
23040	5410	14.7	7.12	1359	361	1495	553	1.45	67.1
33090	7887	15.2	7.43	1891	526	2088	802	2.18	153
43190	10140	15.5	7.49	2400	676	2683	1032	2.89	298
84870	19520	16.3	7.83	4297	1268	4989	1942	6.15	1513
31250	5861	16.3	7.06	1654	391	1824	600	1.95	81.3
37640	6998	16.6	7.20	1960	471	2165	721	2.37	126
45070	8564	16.8	7.34	2311	571	2562	873	2.95	193
57680	10820	17.1	7.40	2884	721	3232	1104	3.82	361
104100	19340	17.9	7.70	4820	1260	5571	1934	7.43	1520
41890	6088	18.2	6.92	1971	406	2183	624	2.58	91.4
55860	8338	18.8	7.27	2568	556	2836	850	3.62	178
63720	9465	18.9	7.29	2896	631	3216	966	4.15	250
79890	11720	19.1	7.33	3551	781	3982	1198	5.27	448
131500	19340	19.8	7.59	5501	1260	6331	1939	9.28	1534
54640	6314	20.0	6.79	2315	421	2576	649	3.31	103
86970	10370	21.0	7.24	3550	691	3949	1059	5.65	318
107200	12620	21.2	7.27	4287	842	4815	1292	7.03	548
161900	19150	21.7	7.46	6180	1252	7094	1932	11.2	1544

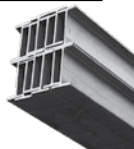
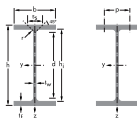

EUROPEAN SPECIFICATION BEAMS WITH PARALLEL FLANGES IN ACCORDANCE WITH EURONORM 53-62

Designation	Weight per Metre G	Depth of Section h	Depth of Section b	Thickness of Web t_w	Thickness of Web t_f	Radius of the Roof Fillet r	Area of Section A	Inner Depth Between Flanges h_i	Depth of Straight Portion of Web h_s
	kg/m	mm	mm	mm	mm	mm	cm ²	mm	mm
HE 550 AA	120	522	300	11.5	15.0	27	153	492	438
HE 550 A	166	540	300	12.5	24.0	27	212	492	438
HE 550 B	199	550	300	15.0	29.0	27	254	492	438
HE 550 M	278	572	306	21.0	40.0	27	354	492	438
HE 600 AA	129	571	300	12.0	15.5	27	164	540	486
HE 600 x 137	137	575	300	11.8	17.5	27	175	540	486
HE 600 x 151	151	582	300	11.6	20.6	27	193	540	486
HE 600 x 174	174	588	300	13.6	23.9	27	223	540	486
HE 600 A	178	590	300	13.0	25.0	27	226	540	486
HE 600 B	212	600	300	15.5	30.0	27	270	540	486
HE 600 M	285	620	305	21.0	40.0	27	364	540	486
HE 650 AA	138	620	300	12.5	16.0	27	176	588	534
HE 650 A	190	640	300	13.5	26.0	27	242	588	534
HE 650 B	225	650	300	16.0	31.0	27	286	588	534
HE 650 M	293	668	305	21.0	40.0	27	374	588	534
HE 700 AA	150	670	300	13.0	17.0	27	191	636	582
HE 700 x 166	166	678	300	12.5	21.0	27	212	636	582
HE 700 A	204	690	300	14.5	27.0	27	260	636	582
HE 700 B	241	700	300	17.0	32.0	27	306	636	582
HE 700 M	301	716	304	21.0	40.0	27	383	636	582
HE 800 AA	172	770	300	14.0	18.0	30	218	734	674
HE 800 A	224	790	300	15.0	28.0	30	286	734	674
HE 800 B	262	800	300	17.5	33.0	30	334	734	674
HE 800 M	317	814	303	21.0	40.0	30	404	734	674
HE 900 AA	198	870	300	15.0	20.0	30	252	830	770
HE 900 A	252	890	300	16.0	30.0	30	321	830	770
HE 900 B	291	900	300	18.5	35.0	30	371	830	770
HE 900 M	333	910	302	21.0	40.0	30	424	830	770
HE 1000 AA	222	970	300	16.0	21.0	30	282	928	868
HE 1000 A	272	990	300	16.5	31.0	30	347	928	868
HE 1000 B	314	1000	300	19.0	36.0	30	400	928	868
HE 1000 M	349	1008	302	21.0	40.0	30	444	928	868

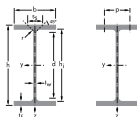

EUROPEAN SPECIFICATION BEAMS WITH PARALLEL FLANGES IN ACCORDANCE WITH EURONORM 53-62

Moment of Inertia		Radius of Modulus		Elastic Sectional Modulus		Plastic Section Modulus		Warping Constant	Torsional Constant
I_y	I_z	i_y	i_z	W_y	W_z	W_{ply}	W_{pic}	I_w	I_t
cm ⁴	cm ⁴	cm	cm	cm ³	cm ³	cm ³	cm ³	dm ⁴	cm ⁴
72870	6767	21.8	6.65	2792	451	3128	699	4.35	127
111900	10820	23.0	7.15	4146	721	4622	1107	7.20	360
136700	13080	23.2	7.17	4971	872	5591	1341	8.87	610
198000	19160	23.6	7.35	6923	1252	7933	1937	13.60	1559
91870	6993	23.7	6.53	3218	466	3623	724	5.40	142
101500	7893	24.1	6.70	2529	526	3952	814	6.13	177
117100	9287	24.7	6.90	4024	619	4483	953	7.32	247
136400	10780	24.7	7.00	4639	719	5202	1109	8.57	374
141200	11270	25.0	7.05	4787	751	5350	1156	9.00	407
171000	13530	25.2	7.08	5701	902	6425	1391	11.00	677
237400	18980	25.6	7.22	7660	1244	8772	1930	16.00	1570
113900	7221	25.5	6.41	3676	481	4160	751	6.59	158
175200	11720	26.9	6.97	5474	782	6136	1205	11.00	458
210600	13980	27.1	6.99	6480	932	7320	1441	13.40	749
281700	18980	27.5	7.13	8433	1245	9657	1936	18.70	1584
142700	7673	27.3	6.34	4260	512	4840	800	8.18	186
168900	9471	28.2	6.69	4982	631	5598	978	10.20	274
215300	12180	28.8	6.84	6241	812	7032	1257	13.40	522
256900	14440	29.0	6.87	7340	963	8327	1495	16.10	839
329300	18800	29.3	7.01	9198	1237	10540	1929	21.50	1595
208900	8134	30.9	6.10	5426	542	6225	857	11.50	243
303400	12640	32.6	6.65	7682	843	8699	1312	18.30	609
359100	14900	32.8	6.68	8977	994	10230	1553	21.90	959
442600	18630	33.1	6.79	10870	1230	12490	1930	27.90	1657
301100	9041	34.6	5.99	6923	603	7999	958	16.30	322
422100	13550	36.3	6.50	9485	903	10810	1414	25.00	749
494100	15820	36.5	6.53	10980	1054	12580	1658	29.60	1150
570400	18450	36.7	6.60	12540	1222	14440	1929	34.90	1683
406500	9501	38.0	5.80	8380	633	9777	1016	21.40	387
553800	14000	40.0	6.35	11190	934	12820	1470	32.20	835
644700	16280	40.1	6.38	12890	1085	14860	1716	37.80	1267
722300	18460	40.3	6.45	14330	1222	16570	1940	43.20	1713

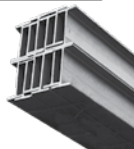
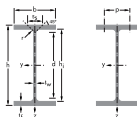

EUROPEAN SPECIFICATION BEAMS WITH PARALLEL FLANGES IN ACCORDANCE WITH EURONORM 53-62

Designation	G	h	b	t _w	t _f	r	A	h ₁	d
	kg/m	mm	mm	mm	mm	mm	cm ²	mm	mm
IPE 100A	6.89	98	55	3.6	4.7	7	8.78	88.6	74.6
IPE 100	8.10	100	55	4.1	5.7	7	10.3	88.6	74.6
IPE 120A	8.66	118	64	3.8	5.1	7	11.0	107.4	93.4
IPE 120	10.4	120	64	4.4	6.3	7	13.2	107.4	93.4
IPE 140 A	10.5	138	73	3.8	5.6	7	13.4	126.2	112.2
IPE 140	12.9	140	73	4.7	6.9	7	16.4	126.2	112.2
IPE 140 R	14.4	142	72	5.3	7.8	7	18.4	126.4	112.4
IPE 160A	12.7	157	82	4.0	5.9	9	16.2	145.2	127.2
IPE 160	15.8	160	82	5.0	7.4	9	20.1	145.2	127.2
IPE 160 R	17.7	162	81	5.6	8.5	9	22.6	145.0	127.0
IPE 180 A	15.4	177	91	4.3	6.5	9	19.6	164.0	146.0
IPE 180	18.8	180	91	5.3	8.0	9	23.9	164.0	146.0
IPE 180 0	21.3	182	92	6.0	9.0	9	27.1	164.0	146.0
IPE 180 R	22.1	183	89	6.4	9.5	9	28.1	164.0	146.0
IPE 200 A	18.4	197	100	4.5	7.0	12	23.5	183.0	159.0
IPE 200	22.4	200	100	5.6	8.5	12	28.5	183.0	159.0
IPE 200 0	25.1	202	102	6.2	9.5	12	32.0	183.0	159.0
IPE 200 R	26.6	204	98	6.6	10.5	12	33.9	183.0	159.0
IPE 220 A	22.2	217	110	5.0	7.7	12	28.3	201.6	177.6
IPE 220	26.2	220	110	5.9	9.2	12	33.4	201.6	177.6
IPE 220 0	29.4	222	112	6.6	10.2	12	37.4	201.6	177.6
IPE 220 R	31.6	225	108	6.7	11.8	12	40.2	201.4	177.4
IPE 240 A	26.2	237	120	5.2	8.3	15	33.3	220.4	190.4
IPE 240	30.7	240	120	6.2	9.8	15	39.1	220.4	190.4
IPE 240 0	34.3	242	122	7.0	10.8	15	43.7	220.4	190.4
IPE 240 R	37.3	245	118	7.5	12.3	15	47.5	220.4	190.4

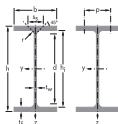

EUROPEAN SPECIFICATION BEAMS WITH PARALLEL FLANGES IN ACCORDANCE WITH EURONORM 53-62

I_y	I_z	i_y	i_z	W_y	W_z	W_{ply}	W_{plz}	I_w	I_t
cm ⁴	cm ⁴	cm	cm	cm ³	cm ³	cm ³	cm ³	dm ⁴	cm ⁴
141	13.1	4.01	1.22	28.8	4.77	33.0	7.54	0.000	0.727
171	15.9	4.07	1.24	34.2	5.79	39.4	9.15	0.000	1.16
257	22.4	4.83	1.42	43.8	7.00	49.9	11.0	0.001	0.996
318	27.7	4.90	1.45	53.0	8.65	60.7	13.6	0.001	1.69
435	36.4	5.70	1.65	63.3	9.98	71.6	15.5	0.002	1.34
541	44.9	5.74	1.65	77.3	12.3	88.3	19.2	0.002	2.40
611	48.8	5.77	1.63	86.1	13.5	99.1	21.3	0.002	3.36
689	54.4	6.53	1.83	87.8	13.3	99.1	20.7	0.003	1.93
869	68.3	6.58	1.84	109	16.7	124	26.1	0.004	3.54
989	75.7	6.62	1.83	122	18.7	140	29.4	0.004	5.05
1063	81.9	7.37	2.05	120	18.0	135	28.0	0.006	2.67
1317	101	7.42	2.05	146	22.2	166	34.6	0.007	4.73
1505	117	7.45	2.08	165	25.5	189	39.9	0.009	6.65
1554	112	7.44	2.00	170	25.2	195	39.7	0.008	7.63
1591	117	8.23	2.23	162	23.4	182	36.5	0.011	4.14
1943	142	8.26	2.24	194	28.5	221	44.6	0.013	6.92
2211	169	8.32	2.30	219	33.1	249	51.9	0.016	9.36
2363	166	8.35	2.21	232	33.8	265	53.2	0.016	11.7
2317	171	9.05	2.46	214	31.2	240	48.5	0.019	5.68
2772	205	9.11	2.48	252	37.3	285	58.1	0.023	9.03
3134	240	9.16	2.53	282	42.8	321	66.9	0.027	12.2
3474	249	9.29	2.49	309	46.1	352	71.8	0.028	16.4
3290	240	9.94	2.68	278	40.0	312	62.4	0.031	8.50
3892	284	9.97	2.69	324	47.3	367	73.9	0.038	13.0
4369	329	10.0	2.74	361	53.9	410	84.4	0.044	17.1
4823	339	10.1	2.67	394	57.4	450	90.1	0.046	22.8

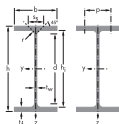

EUROPEAN SPECIFICATION BEAMS WITH PARALLEL FLANGES IN ACCORDANCE WITH EURONORM 53-62

Designation	G	h	b	t_w	t_f	r	A	h_f	d
	kg/m	mm	mm	mm	mm	mm	cm ²	mm	mm
IPE 270 A	30.7	267	135	5.5	8.7	15	39.1	249.6	219.6
IPE 270	36.1	270	135	6.6	10.2	15	45.9	249.6	219.6
IPE 270 0	42.3	274	136	7.5	12.2	15	53.8	249.6	219.6
IPE 270 R	44.0	276	133	7.7	13.1	15	56.0	249.8	219.8
IPE 300 A	36.5	297	150	6.1	9.2	15	46.5	278.6	248.6
IPE 300	42.2	300	150	7.1	10.7	15	53.8	278.6	248.6
IPE 300 0	49.3	304	152	8.0	12.7	15	62.8	278.6	248.6
IPE 300 R	51.7	306	147	8.5	13.7	15	65.9	278.6	248.6
IPE 330 A	43.0	327	160	6.5	10.0	18	54.7	307.0	271.0
IPE 330	49.1	330	160	7.5	11.5	18	62.6	307.0	271.0
IPE 330 0	57.0	334	162	8.5	13.5	18	72.6	307.0	271.0
IPE 330 R	60.3	336	158	9.2	14.5	18	76.8	307.0	271.0
IPE 360 A	50.2	357.6	170	6.6	11.5	18	64.0	334.6	298.6
IPE 360	57.1	360	170	8.0	12.7	18	72.7	334.6	298.6
IPE 360 0	66.0	364	172	9.2	14.7	18	84.1	334.6	298.6
IPE 360 R	70.3	366	168	9.9	16.0	18	89.6	334.0	298.0
IPE 400 A	57.4	397	180	7.0	12.0	21	73.1	373.0	331.0
IPE 400	66.3	400	180	8.6	13.5	21	84.5	373.0	331.0
IPE 400 0	75.7	404	182	9.7	15.5	21	96.4	373.0	331.0
IPE 400 R	81.5	407	178	10.6	17.0	21	104	373.0	331.0
IPE 400 V	84.0	408	182	10.6	17.5	21	107	373.0	331.0
IPE 450 A	67.2	447	190	7.6	13.1	21	85.5	420.8	378.8
IPE 450	77.6	450	190	9.4	14.6	21	98.8	420.8	378.8
IPE 450 0	92.4	456	192	11.0	17.6	21	118	420.8	378.8
IPE 450 R	95.2	458	188	11.3	18.6	21	121	420.8	378.8
IPE 450 V	104	460	194	12.4	19.6	21	132	420.8	378.8

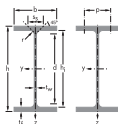

EUROPEAN SPECIFICATION BEAMS WITH PARALLEL FLANGES IN ACCORDANCE WITH EURONORM 53-62

I_y	I_z	i_y	i_z	W_y	W_z	W_{ply}	W_{piz}	I_w	I_t
cm ⁴	cm ⁴	cm	cm	cm ³	cm ³	cm ³	cm ³	dm ⁴	cm ⁴
4917	358	11.2	3.02	368	53.0	412	82.3	0.060	10.4
5790	420	11.2	3.02	429	62.2	484	97.0	0.071	15.9
6947	513	11.4	3.09	507	75.5	575	118	0.088	25.0
7312	516	11.4	3.03	530	77.6	602	121	0.089	29.1
7173	519	12.4	3.34	483	69.2	542	107	0.107	13.3
8356	604	12.5	3.35	557	80.5	628	125	0.126	19.9
9994	746	12.6	3.45	658	98.1	744	153	0.158	31.0
10500	728	12.6	3.32	686	99.0	780	155	0.155	37.0
10230	685	13.7	3.54	626	85.6	702	133	0.172	19.6
11770	788	13.7	3.55	713	98.5	804	154	0.200	28.1
13910	960	13.8	3.64	833	119	943	185	0.247	42.2
14690	958	13.8	3.53	874	121	995	190	0.247	50.6
14520	944	15.1	3.84	812	111	907	172	0.283	27.4
16270	1043	15.0	3.79	904	123	1019	191	0.315	37.4
19050	1251	15.0	3.86	1047	145	1186	227	0.382	55.7
20290	1270	15.0	3.76	1109	151	1262	236	0.389	68.7
20290	1171	16.7	4.00	1022	130	1144	202	0.434	36.2
23130	1318	16.5	3.95	1156	146	1307	229	0.492	51.3
26750	1564	16.7	4.03	1324	172	1502	269	0.590	73.3
28860	1606	16.7	3.93	1418	180	1618	284	0.611	92.5
30140	1766	16.8	4.06	1477	194	1681	304	0.673	99.6
29760	1502	18.7	4.19	1331	158	1494	246	0.707	47.1
33740	1676	18.5	4.12	1500	176	1702	276	0.794	66.7
40920	2085	18.6	4.21	1795	217	2046	341	1.00	109
42400	2070	18.7	4.13	1851	220	2115	346	0.999	123
46200	2397	18.7	4.26	2009	247	2301	389	1.16	149

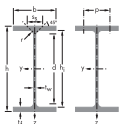

EUROPEAN SPECIFICATION BEAMS WITH PARALLEL FLANGES IN ACCORDANCE WITH EURONORM 53-62

Designation	G	h	b	t_w	t_f	r	A	h_f	d
	kg/m	mm	mm	mm	mm	mm	cm ²	mm	mm
IPE 500A	79.4	497	200	8.4	14.5	21	101	468.0	426.0
IPE 500	90.7	500	200	10.2	16.0	21	116	468.0	426.0
IPE 500 0	107	506	202	12.0	19.0	21	137	468.0	426.0
IPE 500 R	111	508	198	12.6	20.0	21	142	468.0	426.0
IPE 500 V	129	514	204	14.2	23.0	21	164	468.0	426.0
IPE 550 A	92.1	547	210	9.0	15.7	24	117	515.6	467.6
IPE 550	105	550	210	11.1	17.2	24	134	515.6	467.6
IPE 550 0	123	556	212	12.7	20.2	24	156	515.6	467.6
IPE 550 R	134	560	210	14.0	22.2	24	170	515.6	467.6
IPE 550 V	159	566	216	17.1	25.2	24	202	515.6	467.6
IPE 600 A	108	597	220	9.8	17.5	24	137	562.0	514.0
IPE 600	122	600	220	12.0	19.0	24	156	562.0	514.0
IPE 600 0	154	610	224	15.0	24.0	24	197	562.0	514.0
IPE 600 R	144	608	218	14.0	23.0	24	184	562.0	514.0
IPE 600 V	184	618	228	18.0	28.0	24	234	562.0	514.0
IPE 750 x 137	137	753	263	11.5	17.0	17	175	719.0	685.0
IPE 750 x 147	147	753	265	13.2	17.0	17	187	719.0	685.0
IPE 750 x 161	160	758	266	13.8	19.3	17	204	719.4	685.4
IPE 750 x 173	173	762	267	14.4	21.6	17	221	718.8	684.8
IPE 750 x 185	185	766	267	14.9	23.6	17	236	718.8	684.8
IPE 750 x 196	196	770	268	15.6	25.4	17	251	719.2	685.2
IPE 750 x 210	210	775	268	16.0	28.0	17	268	719.0	685.0
IPE 750 x 222	222	778	269	17.0	29.5	17	283	719.0	685.0

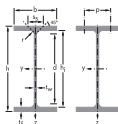

EUROPEAN SPECIFICATION BEAMS WITH PARALLEL FLANGES IN ACCORDANCE WITH EURONORM 53-62

I_y	I_z	i_y	i_z	W_y	W_z	W_{ply}	W_{plz}	I_w	I_t
cm ⁴	cm ⁴	cm	cm	cm ³	cm ³	cm ³	cm ³	dm ⁴	cm ⁴
42930	1939	20.6	4.38	1728	194	1946	302	1.13	64.3
48200	2142	20.4	4.31	1928	214	2194	336	1.25	89.1
57780	2622	20.6	4.38	2284	260	2613	409	1.55	143
59930	2600	20.5	4.28	2360	263	2709	415	1.55	162
70720	3271	20.8	4.47	2752	321	3168	507	1.97	242
59980	2432	22.6	4.55	2193	232	2475	362	1.72	89.3
67120	2668	22.3	4.45	2441	254	2787	401	1.89	123
79160	3224	22.5	4.55	2847	304	3263	481	2.31	187
86600	3447	22.5	4.50	3093	328	3562	521	2.49	242
102300	4265	22.5	4.60	3616	395	4205	632	3.12	372
82920	3116	24.6	4.77	2778	283	3141	442	2.62	122
92080	3387	24.3	4.66	3069	308	3512	486	2.86	165
118300	4521	24.5	4.79	3879	404	4471	640	3.88	316
110300	3993	24.5	4.66	3629	366	4175	580	3.42	271
141600	5570	24.6	4.88	4582	489	5324	780	4.85	506
159900	5166	30.3	5.44	4246	393	4865	614	7.00	135
166100	5289	29.8	5.31	4411	399	5110	631	7.16	157
186100	6073	30.2	5.45	4909	457	5666	720	8.28	208
205800	6873	30.5	5.57	5402	515	6218	810	9.42	270
223000	7510	30.8	5.65	5821	563	6691	884	10.3	334
240300	8175	31.0	5.71	6241	610	7174	959	11.3	406
262200	9011	31.3	5.80	6765	672	7762	1054	12.6	512
278200	9604	31.3	5.82	7152	714	8225	1122	13.5	601

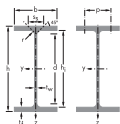

IPN

European Standard Beams

Flange slope : 14%, Dimensions : DIN 1025-1: 1963, NFA 45-209 (1983)

Tolerances : EN 10024: 1985, Surface Condition according to EN 10163-3: 1991, class C, subclass I

Designation		Dimensions						Dimensions for Detailing				
G	h	b	t _w	t _f	r ₁	r ₂	A	d	Ø	P _{min}	P _{max}	
kg/m	mm	mm	mm	mm	mm	mm	mm ²	mm		mm	mm	
							x 10 ²					
IPN 80	5.94	80	42	3.9	80	5.9	3.9	2.3	7.58	59	-	-
IPN 100	8.34	100	50	4.5	100	6.8	4.5	2.7	10.6	757	-	-
IPN 120	11.1	120	58	5.1	120	7.7	5.1	3.1	14.2	924	-	-
IPN 140	14.3	140	66	5.7	140	8.6	5.7	3.4	18.3	109.1	-	-
IPN 160	17.9	160	74	6.3	160	9.5	6.3	3.8	22.8	125.8	-	-
IPN 180	21.9	180	82	6.9	180	10.4	6.9	4.1	27.9	142.4	-	-
IPN 200	26.2	200	90	7.5	200	11.3	7.5	4.5	33.4	159.1	-	-
IPN 220	31.1	220	98	8.1	220	12.2	8.1	4.9	39.5	175.8	M10	56
IPN 240	36.2	240	106	8.7	240	13.1	8.7	5.2	46.1	192.5	M10	60
IPN 260	41.9	260	113	9.4	260	14.1	9.4	5.6	53.3	208.9	M12	62
IPN 280	47.9	280	119	10.1	280	15.2	10.1	6.1	61	225.1	M12	68
IPN 300	54.2	300	125	10.8	300	16.2	10.8	6.5	69	241.6	M12	74
IPN 320	61.0	320	131	11.5	320	17.3	11.5	6.9	77.7	257.9	M12	80
IPN 340	68.0	340	137	12.2	340	18.3	12.2	7.3	86.7	274.3	M12	86
IPN 360	76.1	360	143	13	360	19.5	13	7.8	97	290.2	M12	92
IPN 380	84.0	380	149	13.7	380	20.5	13.7	8.2	107	306.7	M16	86
IPN 400	92.4	400	155	14.4	400	21.6	14.4	8.6	118	322.9	M16	92
IPN 450	115	450	170	16.2	450	24.3	16.2	9.7	147	363.6	M16	106
IPN 500	141	500	185	18	500	27	18	10.8	179	404.3	M20	110
IPN 550	166	550	200	19	550	30	19	11.9	212	445.6	M22	118
IPN 600	199	600	215	21.6	600	32.4	21.6	13	254	485.8	M24	128

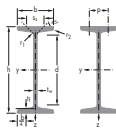

IPN

European Standard Beams

Flange slope : 14%, Dimensions : DIN 1025-I: 1963, NFA 45-209 (1983)

Tolerances : EN 10024: 1985, Surface Condition according to EN 10163-3: 1991, class C, subclass I

Surface		Section Properties											
		Strong Axis					Weak Axis z-z						
A_L	A_G	I_y	W_y	$W_{pl,y}$	i_y	A_{vz}	I_z	W_z	$W_{pl,z}$	i_z	S_S	I_t	$I_w \times 10^{-3}$
m^2/m	m^2/t	mm^4	mm^3	mm^3	mm	mm^2	mm^4	mm^3	mm^3	mm	mm	mm^4	mm^6
		$\times 10^4$	$\times 10^3$	$\times 10^3$	$\times 10$	$\times 10^2$	$\times 10^4$	$\times 10^3$	$\times 10^3$	$\times 10$		$\times 10^4$	$\times 10^9$
0.304	51.09	77.8	19.5	22.8	3.2	3.41	6.29	3	5	0.91	21.6	0.87	0.09
0.370	44.47	171	34.2	39.8	4.01	4.85	12.2	4.88	8.1	1.07	25	1.6	0.27
0.439	39.38	328	54.7	63.6	4.81	6.63	21.5	7.41	12.4	1.23	28.4	2.71	0.69
0.502	34.94	573	81.9	95.4	5.61	8.65	35.2	10.7	17.9	1.4	31.8	4.32	1.54
0.575	32.13	935	117	136	6.4	10.83	54.7	14.8	24.9	1.55	35.2	6.57	3.14
0.640	29.22	1450	161	187	7.2	13.35	81.3	19.8	33.2	1.71	38.6	9.58	5.92
0.709	27.04	2140	214	250	8.00	16.03	117	26	43.5	1.87	42	13.5	10.5
0.775	24.99	3060	278	324	8.80	19.06	162	33.1	55.7	2.02	45.4	18.6	17.8
0.844	23.32	4250	354	412	9.59	22.33	221	41.7	70	2.2	48.9	25	28.7
0.906	21.65	5740	442	514	10.4	26.08	288	51	85.9	2.32	52.6	33.5	44.1
0.966	20.17	7590	542	632	11.1	30.18	364	61.2	103	2.45	56.4	44.2	64.6
1.03	19.02	9800	653	762	11.9	34.58	451	72.2	121	2.56	60.1	56.8	91.8
1.09	17.87	12510	782	914	12.7	39.26	555	84.7	143	2.67	63.9	72.5	129
1.15	16.90	15700	923	1080	13.5	44.27	674	98.4	166	2.8	67.6	90.4	176
1.21	15.89	19610	1090	1276	14.2	49.95	818	114	194	2.9	71.8	115	240
1.27	15.12	24010	1260	1482	15.0	55.55	975	131	221	3.02	75.4	141	319
1.33	14.36	29210	1460	1714	15.7	61.69	1160	149	253	3.13	79.3	170	420
1.48	12.83	45850	2040	2400	17.7	77.79	1730	203	345	3.43	88.9	267	791
1.63	11.60	68740	2750	3240	19.5	95.6	2480	268	456	3.72	98.5	402	1400
1.80	10.80	99180	3610	4240	21.6	111.3	3490	349	592	4.02	107.3	544	2390
1.97	989	138800	4627	5452	23.39	138.0	4674	435	752	4.29	117.6	787	3814

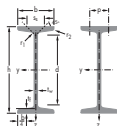

JIS WIDE FLANGE SHAPE

Size	Weight	Depth of Section (A)	Flange Width (B)	Thickness		Corner Radius (r)	Sectional Area	Moment of Inertia		Radius of Gyration		Modulus of Section	
				Web (t_1)	Flange (t_2)			Jx	Jy	ix	iy	Zx	Zy
mm	kg/m	mm	mm	mm	mm	mm	cm	cm ⁴	cm ⁴	cm	cm	cm ³	cm ³
100 x 50	9.30	100	50	5	7	8	11.85	187	14.8	3.98	1.12	37.5	5.91
100 x 100	17.2	100	100	6	8	10	21.90	383	134	4.18	2.47	76.5	26.7
125 x 60	13.2	125	60	6	8	9	16.84	413	29.2	4.95	1.32	66.1	9.73
125 x 125	23.8	125	125	6.5	9	10	30.31	847	293	5.29	3.11	136	47.0
150 x 75	14.0	150	75	5	7	8	17.85	666	49.5	6.11	1.66	88.8	13.2
150 x 100	21.1	148	100	6	9	11	26.84	1020	151	6.17	2.37	138	30.1
150 x 150	31.5	150	150	7	10	11	40.14	1640	563	6.39	3.75	219	75.1
175 x 90	18.1	175	90	5	8	9	23.04	1210	97.5	7.26	2.06	139	21.7
175 x 175	40.2	175	175	7.5	11	12	51.21	2880	984	7.50	4.38	330	112
200 x 100	18.2	198	99	4.5	7	11	23.18	1580	114	8.26	2.21	160	23.0
	21.3	200	100	5.5	8	11	27.16	1840	134	8.24	2.22	184	26.8
200 x 150	30.6	194	150	6	9	13	39.01	2690	507	8.30	3.61	277	67.6
200 x 200	49.9	200	200	8	12	13	63.53	4720	1600	8.62	5.02	472	160
	56.2	200	204	12	12	13	71.53	4980	1700	8.35	4.88	498	167
	65.7	208	202	10	16	13	83.69	6530	2200	8.8-3	5.13	628	218
250 x 125	25.7	248	124	5	8	12	32.68	3540	255	10.4	2.79	285	41.1
	29.6	250	125	6	9	12	37.66	4050	294	10.4	2.79	324	47.0
250 x 175	44.1	244	175	7	11	16	56.24	6120	984	10.4	4.18	502	113
250 x 250	64.4	244	252	11	11	16	82.06	8790	2940	10.3	5.98	720	233
	66.5	248	249	8	13	16	84.70	9930	3350	10.8	6.29	801	269
	72.4	250	250	9	14	16	92.18	10800	3650	10.8	6.29	867	292
	82.2	250	255	14	14	16	104.7	11500	3880	10.5	6.09	919	304
300 x 150	32.0	298	149	5.5	8	13	40.80	6320	442	12.4	3.29	424	59.3
	36.7	300	150	6.5	9	13	46.38	7210	508	12.4	3.29	481	67.7
300 x 200	56.8	294	200	8	12	18	72.38	11300	1600	12.5	4.71	771	160
	65.4	298	201	9	14	18	82.36	13300	1900	12.6	4.77	893	189

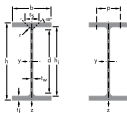
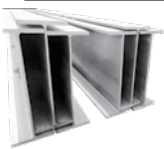

JIS WIDE FLANGE SHAPE

Size	Weight	Depth of Section (A)	Flange Width (B)	Thickness		Corner Radius (r)	Sectional Area	Moment of Inertia		Radius of Gyration		Modulus of Section	
				Web (t _w)	Flange (t _f)			cm ⁴	J _y	i _x	i _y	Z _x	Z _y
mm	kg/m	mm	mm	mm	mm	mm	cm	J _x	cm ⁴	cm	cm	cm ³	cm ³
300 x 300	84.5	294	302	12	12	18	107.7	16900	5520	12.5	7.16	1150	365
	87.0	298	299	9	14	18	110.8	18800	6240	13.0	7.51	1270	417
	94.0	300	300	10	15	18	119.8	20400	6750	13.1	7.51	1360	450
	106	300	305	15	15	18	134.8	21500	7100	12.6	7.26	1440	466
	106	304	301	11	17	18	134.8	23400	7730	13.2	7.57	1540	514
350 x 175	41.4	346	174	6	9	14	52.7	11100	792	14.5	3.88	641	91.0
	49.6	350	175	7	11	14	63.1	13600	984	14.7	3.95	775	112
350 x 250	69.2	336	249	8	12	20	88.1	18500	3090	14.5	5.92	1100	248
	79.7	340	250	9	14	20	101.5	21700	3650	14.6	6.00	1280	292
350 x 350	106	338	351	13	13	20	135.3	28200	9380	14.4	8.33	1,670	534
	115	344	348	10	16	20	146.0	33,300	11,200	15.1	8.78	1,940	646
	131	344	354	16	16	20	166.6	35,300	11,800	14.6	8.43	2,050	669
	137	350	350	12	19	20	173.9	40,300	13,600	15.2	8.84	2,300	776
	156	350	357	19	19	20	198.4	42,800	14,400	14.7	8.53	2,450	809
	159	356	352	14	22	20	202.0	47,600	16,000	15.3	8.90	2,670	909
400 x 200	56.6	396	199	7	11	16	72.16	20,000	1,450	16.7	4.48	1,010	145
	66.0	400	200	8	13	16	84.12	23,700	1,740	16.8	4.54	1,190	174
400 x 300	94.3	386	299	9	14	22	120.1	33,700	6,240	16.7	7.81	1,740	418
	107	390	300	10	16	22	136.0	38,700	7,210	16.9	7.28	1,980	481
400 x 400	140	388	402	15	15	22	178.5	49,000	16,300	16.6	9.54	2,520	809
	147	394	398	11	18	22	186.8	56,100	18,900	17.3	10.1	2,850	951
	168	394	405	18	18	22	214.4	59,700	20,000	16.7	9.65	3,030	985
	172	400	400	13	21	22	218.7	66,600	22,400	17.5	10.1	3,330	1,120
	197	400	408	21	21	22	250.7	70,900	23,800	16.8	9.75	3,540	1,170
	200	406	403	16	24	22	254.9	78,000	26,200	17.5	10.1	3,840	1,300
	232	414	405	18	28	22	295.4	92,800	31,000	17.7	10.2	4,480	1,530
	283	428	407	20	35	22	360.7	119,000	39,400	18.2	10.4	5,570	1,930
	415	458	417	30	50	22	528.6	187,000	60,500	18.8	10.7	8,170	2,900
	605	498	432	45	70	22	770.1	298,000	94,400	19.7	11.1	12,000	4,370
450 x 200	66.2	446	199	8	12	18	84.3	28,700	1,580	18.5	4.33	1,290	159
	76.0	450	200	9	14	18	96.76	33,500	1,870	18.6	4.40	1,490	187

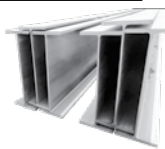
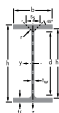

JIS WIDE FLANGE SHAPE

Size mm	Weight kg/m	Depth of Section (A) mm	Flange Width (B) mm	Thickness		Corner Radius (r) mm	Sectional Area cm	Moment of Inertia		Radius of Gyration		Modulus of Section	
				Web (t_1) mm	Flange (t_2) mm			cm ⁴ J _x	J _y cm ⁴	i _x cm	i _y cm	Z _x cm ³	Z _y cm ³
450X300	106	434	299	10	15	24	135.0	46,800	6,690	18.6	7.04	2,160	448
	124	440	300	11	18	24	157.4	56,100	8,110	18.9	7.18	2,550	541
500X200	79.5	496	199	9	14	20	101.3	41,900	1,840	20.3	4.27	1,690	185
	89.6	500	200	10	16	20	114.2	47,800	2,140	20.5	4.33	1,910	214
	103	506	201	11	19	20	131.3	56,500	2,580	20.7	4.43	2,230	257
500X300	114	482	300	11	15	26	145.5	60,400	6,760	20.4	6.82	2,500	451
	128	488	300	11	18	26	163.5	71,000	8,110	20.8	7.04	2,910	541
600X200	94.6	596	199	10	15	22	120.5	68,700	1,980	23.9	4.05	2,310	199
	106	600	200	11	17	22	134.4	77,600	2,280	24.0	4.12	2,590	228
	120	606	201	12	20	22	152.5	90,400	2,720	24.3	4.22	2,980	271
	134	612	202	13	23	22	107.7	103,000	3,180	24.6	4.31	3,380	314
600X300	137	582	300	12	17	28	174.5	103,000	7,670	24.3	6.63	3,530	511
	151	588	300	12	20	28	192.5	118,000	9,020	24.8	6.85	4,020	601
	175	594	302	14	23	28	222.4	137,000	10,600	24.9	6.90	4,620	701
700X300	166	692	300	13	20	28	211.5	172,000	9,020	28.6	6.53	4,980	602
	185	700	300	13	24	28	235.5	201,000	10,800	29.3	6.78	5,760	722
	215	708	302	15	28	28	273.6	237,000	12,900	29.4	6.86	6,700	853
800X300	191	792	300	14	22	28	243.4	254,000	9,930	32.3	6.39	6,410	662
	210	800	300	14	26	28	267.4	292,000	11,700	33.0	6.62	7,290	782
	241	808	302	16	30	28	307.6	339,000	13,800	33.2	6.70	8,400	915
900X300	213	890	299	15	23	28	270.9	345,000	10,300	35.7	6.16	7,760	688
	243	900	300	16	28	28	309.8	411,000	12,600	36.4	6.39	9,140	843
	286	912	302	18	34	28	364.0	498,000	15,700	37.0	6.56	10,900	1,040

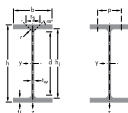
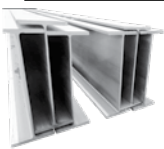

MILD STEEL CHANNELS

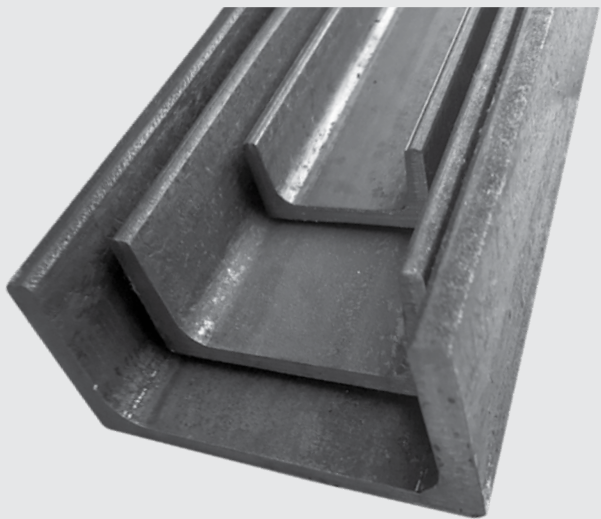

JIS CHANNELS

Size	Weight	Thickness		Corner Radius		Sectional Area	Moment of Inertia		Radius of Gyration		Modulus of Section	
		Web (t_1)	Flange (t_2)	r_1	r_2		J_x	J_y	i_x	i_y	Z_x	Z_y
A x B x t_c	kg/m	mm	mm	mm	mm	cm ²	cm ⁴	cm ⁴	cm	cm	cm ³	cm ³
75x40x5	6.92	5	7	8	4	8.818	75.9	12.4	2.93	1.19	20.2	4.54
100x50x5	9.36	5	7.5	8	4	11.92	189	26.9	3.98	1.50	37.8	7.82
125x65x6	13.4	6	8	8	4	17.11	425	65.5	4.99	1.96	68.0	14.4
150x75x6.5	18.6	6.5	10	10	5	23.71	864	122	6.04	2.27	115	23.6
150x75x9	24.0	9	12.5	15	7.5	30.59	1060	151	5.87	2.22	141	29.1
180x75x7	21.4	7	10.5	11	5.5	27.20	1380	137	7.13	2.24	154	25.5
180x90x7.5	27.1	7.5	12.5	13	6.5	34.57	1840	258	7.29	2.73	204	42.0
200x80x7.5	24.6	7.5	11	12	6	31.33	1950	177	7.89	2.38	195	30.8
200x90x8	30.3	8	13.5	14	7	38.65	2490	286	8.03	2.72	249	45.9
230x80x8	28.4	8	12	13	6.5	36.12	2900	200	8.96	2.35	252	34.2
230x90x8.5	33.1	8.5	13.5	15	7.5	42.14	3490	303	9.10	2.68	304	47.3
250x80x8	30.2	8	12.5	14	7	38.51	3630	210	9.71	2.34	291	35.7
250x90x9	34.6	9	13	14	7	44.07	4180	306	9.74	2.64	335	46.5
250x90x11	40.2	11	14.5	17	8.5	51.17	4690	342	9.57	2.58	375	51.7
280x100x9	38.8	9	13	14	7	49.37	5930	428	11.0	2.95	423	58.2
280x100x11.5	48.2	11.5	16	18	9	61.37	7150	515	10.8	2.90	510	70.4
300x90x9	38.1	9	12	14	7	48.57	6440	325	11.5	2.59	429	48.0
300x90x10	43.8	10	15.5	19	9.5	55.74	7400	373	11.5	2.59	494	56.0
380x100x10.5	54.5	10.5	16	18	9	69.39	14500	557	14.5	2.83	762	73.3
380x100x13	62.0	13	6.5	18	9	78.96	15600	584	14.1	2.72	822	75.8

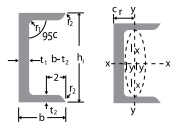
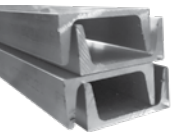

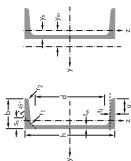
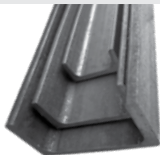

EUROPEAN STANDARD CHANNELS (UPN)
DIMENSIONS: DIN 10261 - 1:2000, NF A 45202 (1983)
TOLERANCES: EN 10279 : 2000

Designation	G kg/m	Dimensions						Dimensions for Detailing					Surface	
		h mm	b mm	t _w mm	t _f mm	r ₁ mm	r ₂ mm	A mm	d mm	Ø	e _{min} mm	e _{max} mm	A _L mm	A _g m ² /t
UPN 80	08.64	80	45	6.0	8.0	8.0	4.00	11.0	46	-	-	0.312	36.13	
UPN 100	10.60	100	50	6.0	8.5	8.5	4.50	13.5	64	M10	31	0.372	35.1	
UPN 120	13.40	120	55	7.0	9.0	9.0	4.50	17.0	82	M10	32	0.434	32.52	
UPN 140	16.00	140	60	7.0	10.0	10.0	5.00	20.4	98	M12	37	0.489	30.54	
UPN 160	18.80	160	65	7.5	10.5	10.5	5.50	24.0	115	M16	38	0.546	28.98	
UPN 180	22.00	180	70	8.0	11.0	11.0	5.50	28.0	133	M16	38	0.611	27.8	
UPN 200	25.30	200	75	8.5	11.5	11.5	6.00	32.2	151	M16	39	0.661	26.15	
UPN 220	29.40	220	80	9.0	12.5	12.5	6.50	37.4	167	M20	44	0.718	24.46	
UPN 240	33.20	240	85	9.5	13.0	13.0	6.50	42.3	184	M20	45	0.775	23.34	
UPN 260	37.90	260	90	10.0	14.0	14.0	7.00	48.3	200	M24	51	0.834	22	
UPN 280	41.80	280	95	10.0	15.0	15.0	7.50	53.3	216	M24	52	0.890	21.27	
UPN 300	46.20	300	100	10.0	16.0	16.0	8.00	58.8	232	M24	53	0.950	20.58	
UPN 320	59.50	320	100	14.0	17.5	17.5	8.75	75.8	246	M24	59	0.982	16.5	
UPN 350	60.60	350	100	14.0	16.0	16.0	8.00	77.3	282	M24	57	1.047	17.25	
UPN 380	63.10	380	102	13.5	16.0	16.0	8.00	80.4	313	M24	57	1.110	17.59	
UPN 400	71.80	400	110	14.0	18.0	18.0	9.00	91.5	324	M27	59	1.182	16.46	

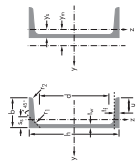
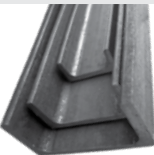

EUROPEAN STANDARD CHANNELS (UPN)
DIMENSIONS: DIN 10261 - I:2000, NF A 45202 (1983)
TOLERANCES: EN 10279 : 2000

Designation	G kg/m	Section Properties										Classification ENV 1993 - 1-1							
		Strong axis y-y					Weak axis z-z					F _{Ed} 255	F _{Ed} 235	F _{Ed} 255	F _{Ed} 235				
		I _w cm ⁴	W _{pl,y} cm ³	I _y cm	A _{v,z} cm ²	I _z cm ⁴	W _{pl,z} cm ³	W _{el,z} cm ³	I _z cm	S _x cm	I _r cm ⁴					I _w × 10 ³ cm ⁴	Y _s cm	Y _m cm	
UPN 80	8.64	106	26.5	31.8	3.1	5.1	194	6.36	12.1	1.33	19.4	2.16	0.17	1.45	2.67	1	1	1	1
UPN 100	10.6	206	41.2	49	3.91	6.46	293	8.49	16.2	1.47	20.3	2.81	0.41	1.55	2.93	1	1	1	1
UPN 120	13.4	364	60.7	72.6	4.62	8.8	432	11.1	21.2	1.59	22.2	4.15	0.9	1.6	3.03	1	1	1	1
UPN 140	16.0	605	86.4	103	5.45	10.41	627	14.8	28.3	1.75	23.9	5.68	1.8	1.75	3.37	1	1	1	1
UPN 160	18.8	925	116	138	6.21	12.6	853	18.3	35.2	1.89	25.3	7.39	3.26	1.84	3.56	1	1	1	1
UPN 180	22.0	1350	150	179	6.95	15.09	114	22.4	42.9	2.02	26.7	9.55	5.57	1.92	3.75	1	1	1	1
UPN 200	25.3	1910	191	228	7.7	17.71	148	27	51.8	2.14	28.1	11.9	9.07	2.01	3.94	1	1	1	1
UPN 220	29.4	2690	245	292	8.48	20.62	197	33.6	64.1	2.3	30.3	16	14.6	2.14	4.2	1	1	1	1
UPN 240	33.2	3600	300	358	9.22	23.71	248	39.6	75.7	2.42	31.7	19.7	22.1	2.23	4.39	1	1	1	1
UPN 260	37.9	4820	371	442	9.99	27.12	317	47.7	91.6	2.56	33.9	25.5	33.3	2.36	4.66	1	1	1	1
UPN 280	41.8	6280	448	532	10.9	29.28	399	57.2	109	2.74	35.6	31	48.5	2.53	5.02	1	1	1	1
UPN 300	46.2	8030	535	632	11.7	31.77	495	67.8	130	2.9	37.3	37.4	69.1	2.7	5.41	1	1	1	1
UPN 320	59.5	10870	679	826	12.1	47.11	597	80.6	152	2.81	43	66.7	96.1	2.6	4.82	1	1	1	1
UPN 350	60.6	12840	734	918	12.9	50.84	570	75	143	2.72	40.7	61.2	114	2.4	4.45	1	1	1	1
UPN 380	63.1	15760	829	1014	14	53.23	615	78.7	148	2.77	40.3	59.1	146	2.38	4.58	1	1	1	1
UPN 400	71.8	20350	1020	1240	14.9	58.55	846	102	190	3.04	44	81.6	221	2.65	5.11	1	1	1	1

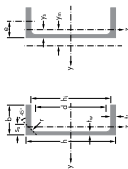

**PARALLEL FLANGE CHANNELS (PFC)
DIMENSIONS: BS 4-1: 1993
TOLERANCES: EN 10279: 2000**

Designation	Mass per metre kg/mtr	Depth of Section h mm	Width of Section h mm	Thickness		Distance of Cy cm	Radius of Root r ₁ mm	Depth between Fillets d mm	Ratios for local Buckling		Second Moment of Area	
				Web s mm	Flange t mm				Flange b/tc	Web d/s	Axis x-x cm ⁴	Axis y-y cm ⁴
100 x 50 x 10	10.2	100	50	5.0	8.5	1.73	9	65	5.88	13.0	13.0	32.3
125 x 65 x 15	14.8	125	65	5.5	9.5	2.25	12	82	6.84	14.9	14.9	80.0
150 x 75 x 18	17.9	150	75	5.5	10.0	2.58	12	106	7.50	19.3	19.3	131
150 x 90 x 24	23.9	150	90	6.5	12.0	3.30	12	102	7.50	15.7	15.7	253
180 x 75 x 20	20.3	180	75	6.0	10.5	2.41	12	135	7.14	22.5	22.5	146
180x 90 x 26	26.1	180	90	6.5	12.5	3.17	12	131	7.20	20.2	20.2	277
200 x 75x 23	23.4	200	75	6.0	12.5	2.48	12	151	6.00	25.2	25.2	170
200 x 90x 30	29.7	200	90	7.0	14.0	3.12	12	148	6.43	21.1	21.1	314
230 x 75 x 26	25.7	230	75	6.5	12.5	2.30	12	181	6.00	27.8	27.8	181
230 x 90 x 32	32.2	230	90	7.5	14.0	2.92	12	178	6.43	23.7	23.7	334
260 x 75 x 28	27.6	260	75	7.0	12.0	2.10	12	212	6.25	30.3	30.3	185
260 x 90 x 35	34.8	260	90	8.0	14.0	2.74	12	208	6.43	26.0	26.0	353
300x 90 x 41	41.4	300	90	9.0	15.5	2.60	12	245	5.81	27.2	27.2	404
300 x 100 x 46	45.5	300	100	9.0	16.5	3.05	15	237	6.06	26.3	26.3	568
380 x 100 x 54	54.0	380	100	9.5	17.5	2.79	15	315	5.71	33.2	33.2	643
430x 100 x 64	64.4	430	100	11.0	19.0	2.62	15	362	5.26	32.9	32.9	772

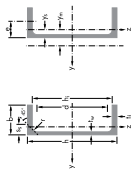

**PARALLEL FLANGE CHANNELS (PFC)
DIMENSIONS: BS 4-1: 1993
TOLERANCES: EN 10279: 2000**

Designation	Radius of Gyration		Elastic Modulus		Plastic Modulus		Buckling Parameter u	Torsional Index x	Ratios for local Buckling		Second Moment of Area	
	Axis x-x cm	Axis y-y cm	Axis x-x cm ³	Axis y-y cm ³	Axis x-x mm ³	Axis y-y cm ³			Flange b/t	Web d/s	Axis x-x cm ⁴	Axis y-y cm ⁴
	100 x 50x10	4.00	1.58	41.5	9.89	48.9	175	0.942	10.0	0.000491	2.53	13.0
125x 65 x 15	5.07	2.06	773	18.8	89.9	33.2	0.942	11.1	0.00194	4.72	18.8	14.8
150x 75 x 18	6.15	2.40	115	26.6	132	47.2	0.946	13.1	0.00467	6.10	22.8	17.9
150x 90 x 24	6.18	2.89	155	44.4	179	76.9	0.936	10.8	0.00890	11.8	30.4	23.9
180x 75x20	7.27	2.38	152	28.8	176	51.8	0.946	15.3	0.00754	7.34	25.9	20.3
180 x 90x26	7.40	2.89	202	47.4	232	835	0.949	12.8	0.0141	13.3	33.2	26.1
200 x 90x 30	8.16	2.88	252	53.4	291	94.5	0.954	12.9	0.0197	183	37.9	29.7
200 x75x23	8.11	2.39	196	33.8	227	60.6	0.956	14.8	0.0107	11.1	29.9	23.4
230 x75x26	9.17	2.35	239	34.8	278	63.2	0.947	173	0.0153	11.8	32.7	25.7
230 x90 x32	9.27	2.86	306	55.0	355	98.9	0.950	15.1	0.0279	19.3	41.0	32.2
260 x75x28	10.1	2.30	278	34.4	328	62.0	0.932	20.5	0.0203	11.7	35.1	27.6
260 x90 x35	10.3	2.82	364	56.3	425	102	0.942	17.2	0.0379	20.6	44.4	34.8
300x 90 x 41	11.7	2.77	481	63.1	568	114	0.934	18.4	0.0581	28.8	52.7	41.4
300x 100 x 46	11.9	3.13	549	81.7	641	148	0.944	17.0	0.0813	36.8	58.0	45.5
380 x 100x54	14.8	3.06	791	89.2	933	161	0.932	21.2	0.150	45.7	68.7	54.0
430 x 100 x 64	16.3	2.97	1020	97.9	1222	176	0.917	223	0.219	63.0	82.1	64.4

**MILD STEEL
EQUAL ANGLES**

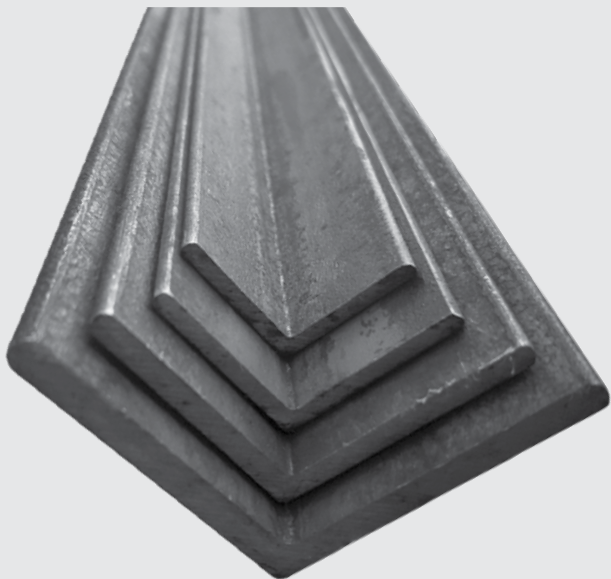

EQUAL ANGLES

TO BS4848 : PART 4

Designation		Mass per meter τ	Area of Section τ	Distance of centre of gravity τ
Size A mm	Thickness mm			
25 x 25	3	1.11	1.42	0.72
	4	1.45	1.85	0.76
	5	1.77	2.26	0.80
40 x 40	4	2.42	3.08	1.12
	5	2.97	3.79	1.16
	6	3.52	4.48	1.20
50 x 50	5	3.77	4.80	1.40
	6	4.47	5.69	1.45
	8	5.82	7.41	1.52
60 x 60	5	4.57	5.82	1.64
	6	5.42	6.91	1.69
	8	7.09	9.03	1.77
	10	8.69	11.1	1.85
65 x 65	5	5.00	6.37	1.77
	6	5.91	7.53	1.81
	7	6.83		
	8	7.66	9.76	1.88
	9	8.26		
	10	9.42	12.00	1.96
70 x 70	6	6.38	8.13	1.83
	8	8.36	10.6	2.01
	10	10.3	13.1	2.09
75 x 75	5	5.78	7.36	1.99
	6	6.87	8.75	2.04
	7	7.94	10.10	2.09
	8	9.00	11.50	2.13
	10	11.10	14.10	2.21
	12	13.10	16.70	2.29

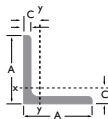

EQUAL ANGLES

TO BS4848 : PART 4

Moment of Inertia	Radius of Gyration	Elastic Modulus	Plastic Modulus
Axis x-x, y-y	Axis x-x, y-y	Axis x-x, y-y	Axis x-x, y-y
cm ⁴	cm	cm ³	cm ³
0.80	0.75	0.45	0.83
1.01	0.74	0.58	1.07
1.20	0.73	0.71	1.30
4.47	1.21	1.55	2.85
5.43	1.20	1.91	3.50
6.31	1.19	2.26	4.13
11.0	1.51	3.05	5.58
12.8	1.50	3.61	6.61
16.3	1.48	4.68	8.55
19.4	1.82	4.45	8.15
22.8	1.82	5.29	9.67
29.2	1.80	6.89	12.57
34.9	1.78	8.41	15.32
24.7	1.98	5.22	
29.2	1.97	6.21	
33.4	1.96	7.18	
37.5	1.95	8.13	
41.4	1.94	9.05	
45.1	1.93	9.94	
36.9	2.13	7.27	13.30
47.5	2.11	9.52	17.37
57.2	2.09	11.70	21.25
38.5	2.29	7.0	
45.6	2.28	8.35	
52.4	2.27	9.67	
58.9	2.27	11.0	
71.2	2.25	13.5	
82.6	2.23	15.8	

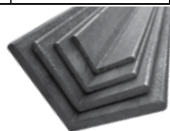
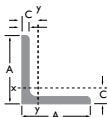

EQUAL ANGLES

TO BS4848 : PART 4

Designation		Mass per meter ρ kg	Area of Section A cm^2	Distance of centre of gravity \bar{c} cm
Size A mm	Thickness t mm			
80 x 80	10	11.9	15.1	2.34
	8	9.63	12.3	2.26
	6	7.34	9.25	2.17
90 x 90	12	15.9	20.3	2.66
	10	13.4	17.1	2.58
	9	12.20	15.50	2.54
	8	10.9	13.9	2.50
	7	9.61	12.20	2.45
	6	8.30	10.6	2.41
100 x 100	15	21.9	27.9	3.02
	12	17.8	22.7	2.90
	10	15.0	19.2	2.82
	8	12.2	15.5	2.74
	6	9.26	11.80	2.64
120 x 120	15	26.60	33.90	3.51
	14	25.00	31.80	3.48
	12	21.60	27.50	3.4
	10	18.20	23.20	3.31
	8	14.70	18.70	3.23
130 x 130	16	30.80	39.30	3.80
	15	29.00	37.00	3.76
	12	23.50	30.00	3.64
	10	19.80	25.20	3.55
150 x 150	20	44.2	56.30	4.44
	19	42.1	53.70	4.40
	18	40.1	51.0	4.37
	15	33.8	43.0	4.25
	12	27.3	34.8	4.12
	10	23.0	29.14	4.03
200 x 200	24	71.1	90.8	5.84
	20	59.9	76.6	5.68
	18	54.2	69.14	5.60
	16	48.5	61.8	5.52

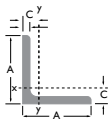
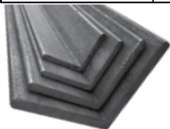

EQUAL ANGLES

TO BS4848 : PART 4

Moment of Inertia	Radius of Gyration	Elastic Modulus	Plastic Modulus
Axis x-x, y-y	Axis x-x, y-y	Axis x-x, y-y	Axis x-x, y-y
cm ⁴	cm	cm ³	cm ³
55.8	2.44	9.57	17.52
72.2	2.43	12.6	22.95
87.5	2.41	15.4	28.15
80.3	2.76	12.2	22.31
92.5	2.75	14.1	
104	2.74	16.1	29.30
116	2.73	17.9	
127	2.72	19.8	36.03
148	2.70	23.3	42.50
111	107	15.1	
145	3.06	19.9	36.43
177	3.04	24.6	44.73
207	3.02	29.1	53.03
249	2.98	35.6	64.77
255	3.69	29.1	
313	3.67	36.0	
368	3.65	42.7	
420	3.63	49.2	
445	3.62	52.4	
401	3.99	42.5	
472	3.97	50.4	
573	3.94	62.0	
605	3.93	65.7	
624	4.62	56.9	103.77
737	4.60	67.7	123.35
898	4.57	83.5	151.85
1050	4.54	98.7	179.37
1100	4.52	104	
1150	4.51	109	
2340	6.16	162	293.49
2850	6.11	199	361.01
2600	6.13	181	327.55
3330	6.06	235	426.20

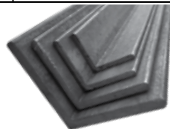
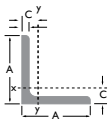



**MILD STEEL
UNEQUAL ANGLES**

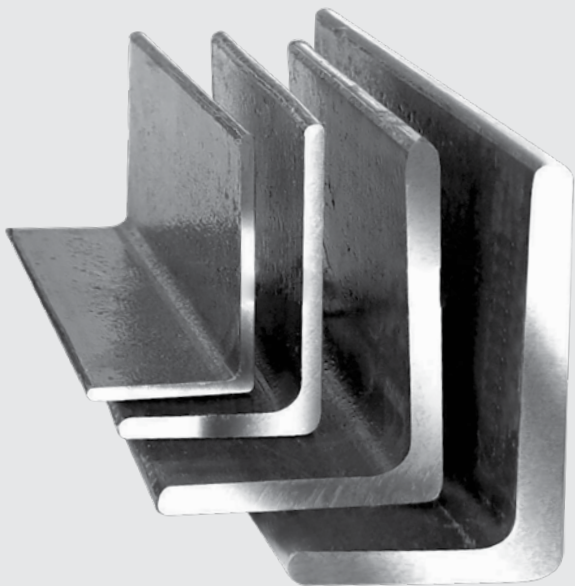

UNEQUAL ANGLES

TO BS4848 : PART 4

Designation		Mass per meter	Area of Section	Distance of centre of gravity		Moment of Inertia Axis x-x cm ³
Size A x B mm	Thickness t mm			C _x cm	C _y cm	
65 x 50	5	4.35	5.54	1.99	1.25	23.2
	6	5.16	6.58	2.04	1.29	27.2
	8	6.75	8.60	2.11	1.37	34.8
75 x 50	6	5.65	7.19	2.44	1.21	40.5
	8	7.39	9.41	2.52	1.29	52.0
	10	9.07	11.60	2.60	1.36	62.6
80 x 60	6	6.37	8.11	2.47	1.48	51.4
	7	7.36	9.38	2.51	1.52	59.0
	8	8.34	10.6	2.55	1.56	66.3
100 x 50	6	6.85	8.73	3.49	1.04	89.7
	8	8.99	11.40	3.59	1.12	116
	10	11.10	14.10	3.67	1.20	141
100 x 65	7	8.77	11.2	3.23	1.51	113
	8	9.94	12.7	3.27	1.55	127
	10	12.3	15.6	3.36	1.63	154
100 x 75	7	9.32	11.90	3.06	1.83	118
	8	10.6	13.5	3.10	1.87	133
	10	13.0	16.6	3.19	1.95	162
	12	15.4	19.7	3.27	2.03	189

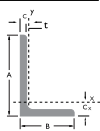

UNEQUAL ANGLES

TO BS4848 : PART 4

Moment of Inertia	Radius of Gyration		Elastic Modulus		Plastic Modulus	
	Axis y-y	Axis x-x	Axis x-x	Axis y-y	Axis x-x	Axis y-y
cm ⁴	cm	cm	cm ³	cm ³	cm ³	cm ³
11.9	2.05	1.47	5.14	3.19	9.41	5.76
14.0	2.03	1.46	6.10	3.77	11.13	6.85
17.7	2.01	1.44	7.93	4.89	14.40	8.94
14.4	2.37	1.42	8.01	3.81	14.54	6.95
18.4	2.35	1.40	10.4	4.95	18.87	9.14
21.9	2.33	1.38	12.8	6.03		
24.8	2.52	1.75	9.29	5.49	17.02	9.96
28.4	2.51	1.74	10.7	6.34	19.63	11.54
31.8	2.50	1.73	12.2	7.16	22.17	13.08
15.3	3.21	1.32	13.8	3.85		
19.5	3.18	1.31	18.1	5.04		
23.4	3.16	1.29	22.2	6.17		
37.6	3.17	1.83	16.6	7.53	30.23	13.77
42.2	3.16	1.83	18.9	8.54	34.21	15.67
51.0	3.14	1.81	23.2	10.5	41.91	19.41
56.9	3.15	2.19	17	10		
64.1	3.14	2.18	19.3	11.4	35.31	20.69
77.6	3.12	2.16	23.8	14.0	43.31	25.55
90.2	3.10	2.14	28.0	16.5	50.97	30.27

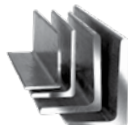
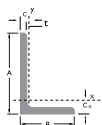

UNEQUAL ANGLES

TO BS4848 : PART 4

Designation		Mass per meter	Area of Section	Distance of centre of gravity		Moment of Inertia Axis x-x
Size A x B mm	Thickness t mm			Cx	Cy	
120 x 80	8	12.20	15.50	3.83	1.87	226
	10	15.00	19.10	3.92	1.95	276
	12	17.80	22.70	4.00	2.03	323
	14	20.50	26.20	4.08	2.10	368
125x 75	8	12.2	15.5	4.14	1.68	247
	10	15.0	19.1	4.23	1.76	302
	12	17.8	22.7	4.31	1.84	354
150 x 75	10	17.0	21.6	5.32	1.61	501
	12	20.2	25.7	5.41	1.69	589
	15	24.8	31.6	5.53	1.81	713
150 x 90	10	18.2	23.2	5.00	2.04	533
	12	21.6	27.5	5.08	2.12	627
	15	26.6	33.9	5.21	2.23	761
150 x 100	10	19.00	24.20	4.80	2.34	552
	12	22.60	28.70	4.89	2.42	650
	14	26.10	33.20	4.97	2.5	743
	15	27.8	35.40	5.01	2.54	789
200 x 100	10	23.0	29.2	6.93	2.01	1220
	12	27.3	34.8	7.03	2.10	1440
	15	33.7	43.0	7.16	2.22	1758
200 x 150	12	32.0	40.8	6.08	3.61	1652
	15	39.6	50.5	6.21	3.73	2022
	18	47.1	60.0	6.33	3.85	2376

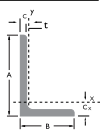

UNEQUAL ANGLES

TO BS4848 : PART 4

Moment of Inertia	Radius of Gyration		Elastic Modulus		Plastic Modulus	
Axis y-y	Axis x-x	Axis y-y	Axis x-x	Axis y-y	Axis x-x	Axis y-y
cm ⁴	cm	cm	cm ³	cm ³	cm ³	cm ³
80.8	3.82	2.28	27.6	13.2		
98.1	3.8	2.26	34.1	16.2		
114	3.77	2.24	40.4	19.1		
130	3.75	2.22	46.4	22		
67.6	4.00	2.09	29.6	11.6	53.33	21.19
82.1	3.97	2.07	36.5	14.3	65.57	26.34
95.5	3.95	2.05	43.2	16.9	77.36	31.42
85.8	4.81	1.99	51.8	14.6	91.04	27.11
99.9	4.79	1.97	61.4	17.2	107.6	32.51
120	4.75	1.94	75.3	21.0	131.45	40.59
146	4.80	2.51	53.3	21.0	95.83	38.20
171	4.77	2.49	63.3	24.8	113.4	45.60
205	4.74	2.46	77.7	30.4	138.77	56.53
198	4.78	2.86	54.1	25.8		
232	4.75	2.84	64.2	30.6		
264	4.73	2.82	74.1	35.2		
280	4.72	2.81	79.0	37.5		
210	6.46	2.68	93.2	26.3	164.91	48.16
247	6.43	2.67	111.0	31.3	195.68	57.82
299	6.40	2.64	137.0	38.4	240.46	72.25
803	6.36	4.44	119.0	70.5	216.97	126.54
979	6.33	4.40	147.0	86.9	267.38	156.62
1146	6.29	4.37	174.0	103.0	316.19	186.02

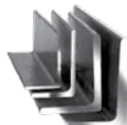
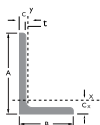

HOT ROLLED STEEL PLATES

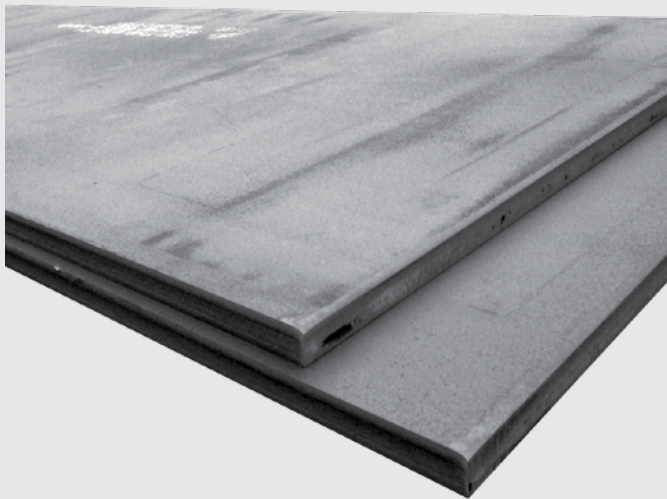

HOT ROLLED STEEL PLATES

Width: 2m / 2.5m / 3.05 | Length: 6m / 8m / 10m / 12m | Thickness: 4mm to 60mm

Boiler / Pressure Vessels Grades - ASTM / ASME 60 / 65/70 (Normalized / NAC

Ship Building Grades - ABS Grade A / B / C / AH32 / AH36 / EH 36

Offshore Grades - S355J2 / S355K2 / API2H50

Commercial Grades - ASTM A36 / S275JR / S355JR / S355JO

Origins: Western Europe/ Korea/ Japan/ Ukraine/ Indonesia/ India/ China

**MILD STEEL ROUND &
SQUARE BARS**

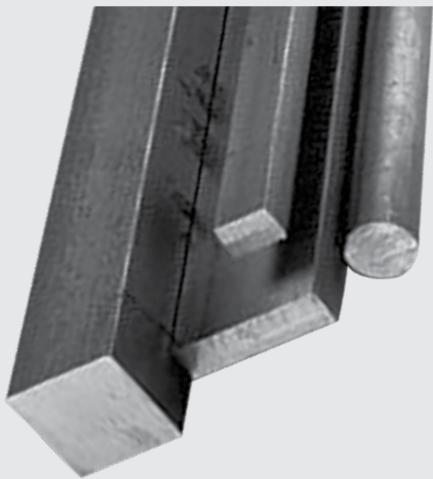

MILD STEEL ROUNDS

Metric Size (mm)	kg/m	Mtrs / Tonne
6	0.22	4505
8	0.39	2532
10	0.62	1621
12	0.89	1120
16	1.58	632
20	2.47	404
25	3.85	259
32	6.31	158
40	9.86	101
45	12.50	80
50	15.40	64
60	22.20	45
65	26.00	38
75	34.70	29
90	49.90	20
100	61.60	16

SQUARE BARS

Metric Size (mm)	kg/m	Mtrs / Tonne
8	0.50	2000
10	0.79	1265
12.5	1.22	820
16	2.01	497
20	3.14	318
25	4.91	204
30	7.07	141
32	8.04	125
40	12.60	80
45	15.90	63
50	19.60	51
60	28.30	35
75	44.20	23
90	63.60	16
100	78.50	13

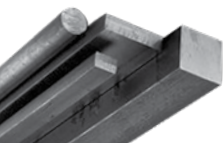

SHAFTING / BRIGHT BARS



Shafting Bars

Description	Kg/pc
M.S. Shafting Bar - 10 mm x 6 mtr	3.7
M.S. Shafting Bar - 12 mm x 6 mtr	5.32
M.S. Shafting Bar - 14 mm x 6 mtr	7.25
M.S. Shafting Bar - 16 mm x 6 mtr	9.47
M.S. Shafting Bar - 19 mm x 6 mtr	13.36
M.S. Shafting Bar - 20 mm x 6 mtr	14.8
M.S. Shafting Bar - 22 mm x 6 mtr	17.91
M.S. Shafting Bar - 25 mm x 6 mtr	23.13
M.S. Shafting Bar - 28 mm x 6 mtr	28.94
M.S. Shafting Bar - 30 mm x 6 mtr	33.3
M.S. Shafting Bar - 32 mm x 6 mtr	37.88
M.S. Shafting Bar - 36 mm x 6 mtr	47.95
M.S. Shafting Bar - 38 mm x 6 mtr	53.42
M.S. Shafting Bar - 40 mm x 6 mtr	59.2
M.S. Shafting Bar - 45 mm x 6 mtr	74.92
M.S. Shafting Bar - 50 mm x 6 mtr	92.5
M.S. Shafting Bar - 55 mm x 6 mtr	111.92
M.S. Shafting Bar - 60 mm x 6 mtr	132.9
M.S. Shafting Bar - 65 mm x 6 mtr	156.32
M.S. Shafting Bar - 70 mm x 6 mtr	181
M.S. Shafting Bar - 75 mm x 6 mtr	208.12
M.S. Shafting Bar - 80 mm x 6 mtr	236
M.S. Shafting Bar - 90 mm x 6 mtr	299.7
M.S. Shafting Bar - 100 mm x 6 mtr	369.2



MILD STEEL FLATS

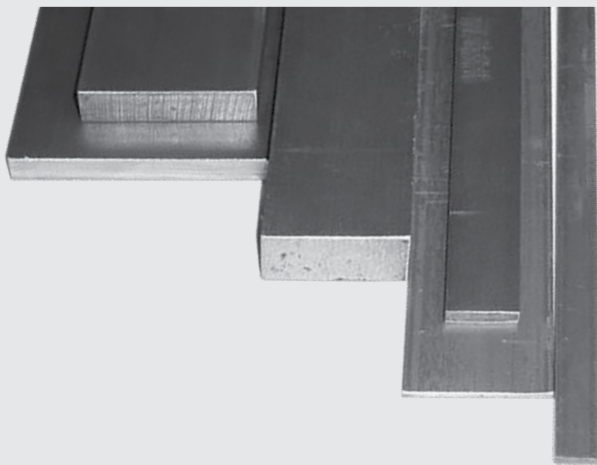

MILD STEEL FLATS (I)

Metric Size (mm)	kg/m	Mtrs / Tonne	Metric Size (mm)	kg/m	Mtrs / Tonne
13 x 3	0.307	3257	40 x 10	3.140	318
13 x 6	0.611	1637	40 x 12	3.768	265
16 x 3	0.378	2648	40 x 15	4.710	212
			40 x 20	6.280	159
20 x 3	0.471	2146	40 x 25	7.850	127
20 x 5	0.785	1274	40 x 30	9.420	106
20 x 6	0.940	1064			
20 x 10	1.570	637	45 x 3	1.060	943
			45 x 6	2.120	472
25 x 3	0.589	1698	45 x 8	2.830	353
25 x 5	0.981	1019	45 x 10	3.530	283
25 x 6	1.180	847	45 x 12	4.240	236
25 x 8	1.570	637	45 x 20	7.070	141
25 x 10	1.960	510	45 x 25	8.830	113
25 x 12	2.355	424			
			50 x 3	1.18	847
30 x 3	0.707	1414	50 x 5	1.96	510
30 x 5	1.180	847	50 x 6	2.36	424
30 x 6	1.410	709	50 x 8	3.14	318
30 x 8	1.884	532	50 x 10	3.93	254
30 x 10	2.355	424	50 x 12	4.71	212
30 x 12	2.826	353	50 x 15	5.89	170
30 x 20	4.710	212	50 x 20	7.85	127
			50 x 25	9.81	102
35 x 6	1.650	606	50 x 30	11.80	85
35 x 10	2.750	364	50 x 40	15.70	64
35 x 12	3.30	303			
35 x 20	5.50	182	55 x 10	4.56	219
40 x 3	0.942	1061	60 x 8	3.77	265
40 x 5	1.570	637	60 x 10	4.71	212
40 x 6	1.884	532	60 x 12	5.65	177
40 x 8	2.512	398	60 x 15	7.07	141

MILD STEEL FLATS (2)

Metric Size (mm)	kg/m	Mtrs / Tonne	Metric Size (mm)	kg/m	Mtrs / Tonne
60 x 20	9.42	106	80 x 12	7.54	113
60 x 25	11.80	85	80 x 15	9.42	106
60 x 30	14.14	71	80 x 20	12.60	79
65 x 5	2.55	392	80 x 25	15.70	64
65 x 6	3.06	327	80 x 30	18.80	53
65 x 8	4.05	247	80 x 40	25.10	40
65 x 10	5.10	196	80 x 50	31.40	32
65 x 12	6.12	163	90 x 6	4.24	236
65 x 15	7.65	131	90 x 10	7.07	141
65 x 20	10.20	98	90 x 12	8.48	118
65 x 25	12.80	78	90 x 15	10.60	94
65 x 30	15.30	66	90 x 20	14.10	71
65 x 40	20.40	49	90 x 25	17.70	57
70 x 8	4.40	227	100 x 5	3.93	254
70 x 10	5.50	182	100 x 6	4.71	212
70 x 12	6.59	151	100 x 8	6.28	159
70 x 20	11.00	97	100 x 10	7.85	127
70 x 25	13.70	73	100 x 12	9.42	106
75 x 6	3.54	284	100 x 15	11.80	85
75 x 8	4.71	212	100 x 20	15.70	64
75 x 10	5.90	169	100 x 25	19.60	51
75 x 12	7.07	142	100 x 30	23.60	43
75 x 15	8.84	113	100 x 40	31.40	32
75 x 20	11.78	84	100 x 50	39.30	26
75 x 25	14.72	68	110 x 6	5.18	193
75 x 30	17.68	57	110 x 10	8.64	116
80 x 6	3.77	265	110 x 12	10.40	96
80 x 8	5.02	199	110 x 20	17.30	58
80 x 10	6.28	159	110 x 50	43.20	23

MILD STEEL FLATS (3)

Metric Size (mm)	kg/m	Mtrs / Tonne	Metric Size (mm)	kg/m	Mtrs / Tonne
120 x 6	5.65	177	180 x 6	8.50	171
120 x 10	9.42	106	180 x 10	14.14	71
120 x 12	11.30	89	180 x 12	17.06	59
120 x 15	14.10	71	180 x 15	21.20	47
120 x 20	18.80	53	180 x 20	28.30	35
120 x 25	23.60	42	180 x 25	35.30	28
130 x 6	6.10	164	200 x 6	9.90	106
130 x 8	8.16	122	200 x 10	15.70	64
130 x 10	10.20	98	200 x 12	18.80	53
130 x 12	12.20	84	200 x 15	23.60	42
130 x 15	15.30	67	200 x 20	31.40	32
130 x 20	20.40	49	200 x 25	39.20	25
130 x 25	25.50	39	200 x 30	47.20	21
140 x 6	6.60	151	220 x 10	17.25	58
140 x 10	11.00	91	220 x 15	25.87	23
140 x 12	13.20	76	220 x 20	34.50	29
140 x 20	22.0	46	220 x 25	43.20	23
150 x 6	7.06	142	250 x 10	19.60	51
150 x 8	9.42	106	250 x 12	23.60	42
150 x 10	11.80	85	250 x 15	29.40	34
150 x 12	14.10	71	250 x 20	39.20	26
150 x 15	17.70	57	250 x 25	49.10	20
150 x 20	23.60	42	250 x 40	78.40	13
150 x 25	29.40	34	250 x 50	98.10	10
160 x 10	12.60	79	280 x 12.5	27.48	36
160 x 12	15.10	66	300 x 10	23.55	43
160 x 15	18.80	53	300 x 12	28.30	35
160 x 20	25.20	40	300 x 15	35.30	28
			300 x 20	47.10	21
			300 x 25	58.80	17
			300 x 40	94.20	11

COILS & SHEETS



Product Type & Applicable Specifications

Description	Hot-Dip Galvanized (HDG) Flat Steel (Coil/Strip/Sheet)
Specification	<p>ASTMA 653/A 653 M - 07 CS Type A, B, C FS Type A, B DDS Type A, B SS Grade 33, 37, 40, 50, 55, 80</p> <p>DIN EN 10327 - 2004 / DIN EN 10346 - 2009 DX51D, DX52D, DX53D</p> <p>DIN EN 10326 - 2004 / DIN EN 10346 - 2009 S220GD, S250GD, S280GD, S320GD, S350GD, S550GD</p> <p>JIS G 3302 - 2007 SGCC, SGCD1, SGCD2, SGC340, SGC400, SGC440, SGC490, SGC570</p>
Type	Tension Levelled / Non Tension Levelled (Full Hard)
Standard Coating Offered	Z90 (G30), Z120 (G40), Z180 (G60), Z275 (G90), Z350(G115)
Surface Finish	Regular Spangle/ Minimum Spangle / Skinpassed
Surface Treatment	Passivated / Non Passivated / Oiled / Unoiled

* other intermediate coatings can be supplied after mutual agreement.

Product Size & Form in Hot-Dip Galvanized Material

Thickness Range (mm)	Width Range (mm)	Form	Remarks
0.28 - 4.00	900 - 1500	Coil form / Sheet	Mill Edge
0.28 - 4.00	650 - 1500	Coil form / Sheet	Trimmed Edge
0.30 - 4.00	≥ 30	Coil form / Sheet	Slitted Coil
0.30 - 4.00	650 - 1500	Coil form / Sheet	Trimmed Edge

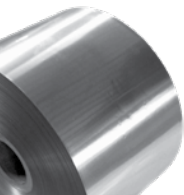

Product Type & Applicable Specifications

Description	Hot-Rolled Steel (Coil/Strip/Sheets)
Specification	<p>JIS G 3101 / G 3131 SS330, SS400, SS490, SS540</p> <p>ASTM ASTM A36 / A572 Gr. 42 / A572 Gr. 50</p> <p>DIN 17100 DIN St 32 / St 37-2 / St 44-2 / St 50-2 / St 52-3</p> <p>BS 4360 / 1986 EN 10025 43A / 43B / 43C / 50A / 50B / 50C / S275JR / S235JR</p>
Width Tolerance	<p>Width upto 2000mm : -0/+20mm Width ≥ 1500mm : -0/+25mm</p>

Product Size & Form Hot Rolled Material

Thickness Range (mm)	Width Range (mm)	Form	Remarks
1.00 - 20.00	1000 - 2000	Coil form	Mill Edge
1.00 - 20.00	650 - 2000	Coil form	Mill Edge
1.00 - 3.00	≥ 100	Coil form	Slitted Edge
1.00 - 15.07	1200 - 3000	2400 - 6000 Sheet	Cut to Length

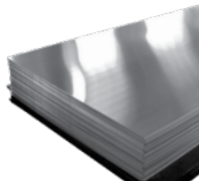

Product type & Applicable Specification

General -Purpose Cold -Rolled Steel Sheets and Coils (JIS G3141)

Description	Cold Rolled Steel (Coil/Strip/Sheets)
Commercial Quality	JIS 3141 SPCC , JIS 3141 SPCC.T.
Drawing Quality	JIS 3141 SPCD.
Deep Drawing Quality	JIS 3141 SPCE , JIS 3141 SPCF.
Extra Deep Drawing Quality	JIS 3141 SPCG.

*other grade can be supplied on mutual agreement.

Product Size & Form in Cold-Rolled Material.

Thickness Range (mm)	Width Range (mm)	Form	Remarks
0.40mm-2.00mm	900 - 1250	Coil form	Mill Edge
0.40mm-2.00mm	250-1250	Coil form	Trimmed Edge
0.40mm-2.00mm	greater than or equal to 30	Coil form	Slitted Edge
0.40mm-2.00mm	1000-1250	2400-6000	Cut to length

Product type & Applicable Specification

Aluminium Plain Sheets
 Grade :AA1100/AA1200 /
 Size /Width : 4' x 8'
 Thickness : 0.4 mm to 10.0 mm

Aluminium Chequered Sheets
 Grade :AA1100/AA1200 /
 Size /Width : 4' x 8'
 Thickness : 1.5 mm to 6.0 mm

Aluminium Coils
 Grade :AA1100/AA1200 /
 Size /Width : 1219mm / 1500mm
 Thickness : 0.5 mm to 3.0mm

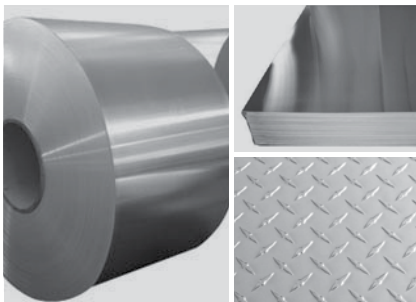

CHEQUERED PLATES

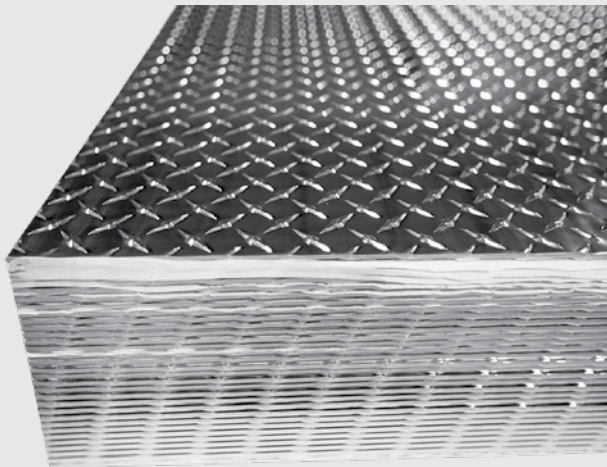

CHEQUERED PLATES

ASTM A36 / S275JR/ SS400

Width: 1219mm x 2438mm

Thickness: 1.8mm to 10mm

Width: 1500mm x 6000mm

Thickness: 3.0mm to 10mm

STAINLESS STEEL PRODUCTS

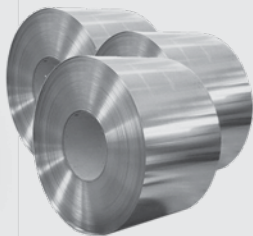

Stainless Steel Sheets

Finish	Grade	Size	Thickness
Mill Finish	201 304 316L 310S	4' x 8' 4' x 10' 5' x 10' 5' x 10' 2 Mtr. x 6 Mtr.	0.50mm to 30mm
2B Finish	201 304 316L	4' x 8' 4' x 10' 5' x 10'	0.50mm to 30mm
Brush Finish	304 316L 201	4' x 8' 4' x 10' 5' x 10'	0.50mm to 30mm
Hairline Finish	304 316L 201	4' x 8' 4' x 10' 5' x 10'	0.50mm to 30mm
Mirror Finish	304 316L 201	4' x 8' 4' x 10' 5' x 10'	0.50mm to 30mm
Titanium Gold / Bronze / Rose Gold / Blue / Black Mirror / Brush / Hairline	304 316L 201	4' x 8' 4' x 10' 5' x 10'	0.50mm to 30mm
Etching Sheets Titanium Gold / Bronze / Rose Gold / Blue / Black Mirror / Brush / Hairline	304 316L 201	4' x 8' 4' x 10' 5' x 10'	0.50mm to 30mm

Stainless Steel Coils

Finish	Grade	Size	Thickness
Mill Finish	201	1219mm	0.50mm to 16mm
2B Finish	304	1500mm	
Brush Finish	316L	2000mm	

Round Bars

Finish	Grade	Size	Thickness
Bright Finish/ Mill Finish	304	3MTR	3mm - 50mm
	316L	4MTR	3mm - 50mm
		6MTR	3mm - 50mm

Pipes

Finish	Grade	Size	Thickness
Mill Finish	304	3 / 8" to 6"	1.20 - 2mm
Mirror Polish Finish	316L		Sch 5 - Sch 80
Brush	201		

TUBES (SHS / RHS)

Finish	Grade	Size	Thickness
Brush Finish	304	10 x 10 - 100 x 100	1.20mm - 4mm
Hairline Finish	316L	20 x 10 - 200 x 100	1.20mm - 4mm
Mirror Finish	201		

ANGLES

Finish	Grade	Size	Thickness
Mill Finish	304	20 x 20 - 150 x 150	1.50 - 12mm
	316L	20 x 20 - 150 x 150	1.50 - 12mm

CHANNELS

Finish	Grade	Size	Length
Mill Finish	304	25 x 50 - 150 x 75	6MTR
	316L	25 x 50 - 150 x 75	6MTR

FLAT BAR

Finish	Grade	Size	Length	Thickness
Mill Finish	304	20 - 100	6MTR	3mm - 10mm
Mill Finish	316L	20 - 100	6MTR	3mm - 10mm

**STAINLESS STEEL
BRIGHT WIRES**





Product	Size Range	Tolerance	Surface	Coil Weight	Tensile req.	Grades
1/8 Hard	0.8 – 11.80mm	Optional – according to requirement	Matte Finish/ Powder Drawn or Oil Drawn/ Bright	300kg max (for 0.8 to 1.2mm) 600kg max (for 1.20- 3.00mm) 800kg max (for 3.00mm & above)	Requirement	304/316/303/ 204Cu/316Ti/ 314 etc.
1/4 Hard	0.8 – 11.80mm	Optional – according to requirement	Matte Finish/ Powder Drawn or Oil Drawn/ Bright	300kg max (for 0.8 to 1.2mm) 600kg max (for 1.20- 3.00mm) 800kg max (for 3.00mm & above)	900 – 1200 N/mm ² or as per requirement	304/316/303/ 204Cu/316Ti/ 314etc.
3/4 Hard	0.8 – 10.00mm	Optional – according to requirement	Matte Finish/ Powder Drawn	300kg max (for 0.8 to 1.2mm) 500kg max (for 1.20-10.00mm)	1100 – 1400 N/mm ² or as per requirement	304/316 204Cu/316Ti/ 314 etc.
Spring Hard (reels)	0.8 – 2.00mm	Optional – according to requirement	Powder Drawn	450 Kg/reels	As per EN 10270-3/ ASTM A313	304/302/316/ 204Cu etc.
Spring Hard (coils)	0.8 – 10.00mm	Optional – according to requirement	Powder Drawn	300kg max (for 0.8 to 1.2mm) 500kg max (for 1.20-10.00mm)	As per EN 10270-3/ ASTM A313	304/302/316/ 204Cu etc.
Soft Annealed	0.8 – 8.00mm	Optional – according to requirement	Matte Finish	600kg max	600 – 700 N/mm ² or as per requirement	304/316/303/ 204Cu/316Ti/ 314 etc.
Bright Annealed	0.8 – 8.00mm	Optional – according to requirement	Bright Finish	600kg max	550 – 700 N/mm ² or as per requirement	304/316/303/ 204Cu/316Ti/ 314 etc.



Product	Size Range	Tolerance	Surface	Coil Weight	Tensile req.	Grades
EPQ	0.8 – 8.00mm	Optional – according to requirement	Mirror Bright finish	300kg max (for 0.8 to 1.2mm) 600kg max (for 1.20-3.00mm) 800kg max (for 3.00mm & above)	700 – 850 N/mm ² or as per requirement	304/316/303/ 204/Cu/316Ti/ 314 etc.
Euro Coils	3.00 – 12.00mm	Optional – according to requirement	Oil Drawn/ Bright	800 – 1200 kg approx.	-	304/316/303/ 204/Cu/316Ti/ 314 etc.
Cold Heading Wires	0.8 to 2.00mm	Optional – according to requirement	Powder Drawn or Oil Drawn	300kg max (for 0.8 to 1.2mm) 600kg max (for 1.20-3.00mm) 800kg max (for 3.00mm & above)	450 – 600N/mm ² or as per requirement	302HQ/304HC/ 409 etc.
Staple Wires	0.70 – 3.00mm	Optional – according to requirement	Oil Drawn/ Bright	500Kgs max Coils or Reels (as per requirement)	850 ~ 1300N/mm ² or as per requirement	304/L, 316/L etc

**STAINLESS STEEL
BRIGHT BARS**



Product	Size Range	Tolerance	Lenght	Value Addition
Round Bars (CD/PO)	3.00 - 30.00mm (1/8" to 1-3/16")	ASTMA484 , or as per requirement +/- 0.0005"	2.0 to 7.0 Mtrs (tolerance of +/-5mm)	Chamfering of sizes 9.52mm and above
Round Bars (CG/PO)	5.00 - 30.00mm (3/16" to 1-3/16")	ASTMA484 , or as per requirement +/- 0.0005"	2.0 to 7.0 Mtrs (tolerance of +/- 5mm)	Chamfering of sizes 9.52mm and above
Square Bars	5.00 - 25.40 mm (3/16" to 1")	ASTMA484 , or as per requirement	2.0 to 7.0 Mtrs (tolerance of+/-5mm)	
Hex Bars	6.00 - 25.40mm (3/16" to 1")	ASTMA484, or as per requirement	2.0 to 7.0 Mtrs (tolerance of+/- 5mm)	
Threaded Bars (Stud Bars)	6.00 - 20.00mm (1/4" to 3/4")	As per requirement	2.0 to 4.0 Mtrs (tolerance+/-5mm)	



GI WIRES



GI WIRES

Tensile Class

Soft

Medium

Diameter

1.60mm - 6.00mm

1.60mm - 6.00mm

Tensile range

400N/mm - 600N/mm

550N/mm - 750N/mm

Diameter in 'mm'	Class A in 'g/m ² '	Class AB in 'g/m ² '	Class B in 'g/m ² '	Class C in 'g/m ² '	Class D in 'g/m ² '
1.65 to 1.85	205	145	100	75	30
1.85 to 2.15	215	155	115	80	40
2.15 to 2.50	230	170	125	85	45
2.50 to 2.80	245	185	125	95	45
2.80 to 3.20	255	195	135	100	50
3.20 to 3.80	265	210	135	105	60
3.80 to 4.40	275	220	135	105	60
4.40 to 5.20	280	220	150	110	70

MILD STEEL GRATINGS

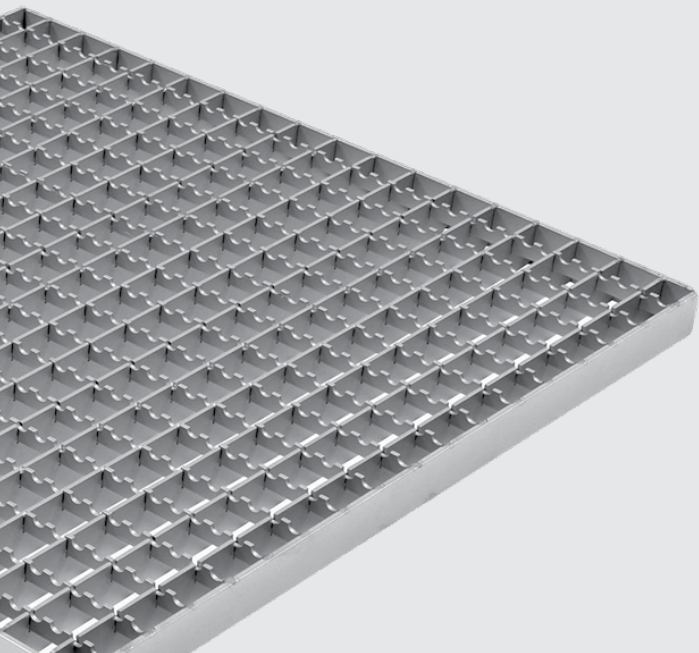

GRATING

TYPE - PLAIN OR SERRATED

PANELSIZE - 1M X 6M

SPECIFICATION - The load bearing bar confirms to the ASTM A36, BS4360 GR43A or equivalent grade

Load Bearing Bar (mm)	Pitch Size (mm)	Mass Kg/m ²
20 x 3 mm	30 x 100	18.85
	40 x 100	14.60
20 x 5 mm	30 x 100	29.51
	40 x 100	22.45
25x 3 mm	30 x 100	22.80
	40 x 100	17.55
30 x 3 mm	30 x 100	26.85
	40 x 100	20.50
30 x 5 mm	30 x 100	42.87
	40 x 100	32.27
32 x 3 mm	30 x 100	28.45
	40 x 100	21.67
32 x5 mm	30 x 100	45.54
	40 x 100	34.24
35 x 3 mm	30 x 100	30.85
	40 x 100	23.43
40 x 3 mm	30 x 100	34.90
	40 x 100	26.40
40 x 5 mm	30 x 100	56.20
	40 x 100	42.10

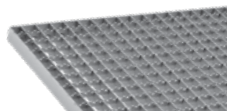

EXPANDED METAL

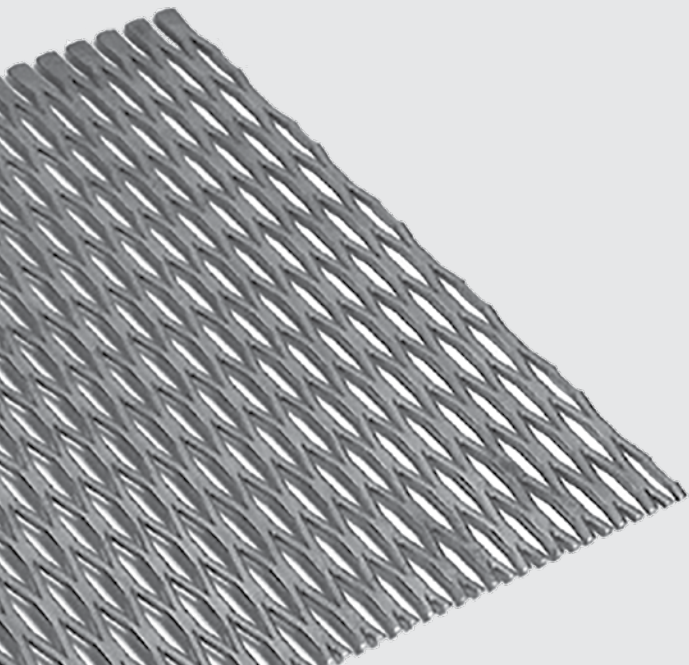

Expanded Metal Mesh

Specification: JIS G3131 SPHC

Size	Weight / Pc (Kg)
4' x 8' x 2mm x 35 x 70	7.46 kg
4' x 8' x 2.3mm x 35 x 70	8.0 kg
4' x 8' x 3.0mm x 35 x 70	13.9 kg
4' x 8' x 3.2mm x 35 x 70	16.0 kg
4' x 8' x 4.0mm x 35 x 70	27.0 kg
4' x 8' x 4.5mm x 35 x 70	0.9 kg
4' x 8' x 6.0mm x 35 x 70	54.4 kg
4' x 8' x 8.0mm x 35 x 70	93.3 kg

GRADES & SPECIFICATIONS



STEEL GRADES Structural Steel

Structural Steel grades according to the following national and international standards can be supplied :

Structural Steels						Designation
EN 10025	ASTM	JIS G 3101 JIS G 3106	CSA G 40 - 21	BS 4360		
Fe 360 B	-	-	-	-	S 235 JR	
Fe 360 B FN	-	-	-	-	S 235 JRG 2	
Fe 360 C	-	-	-	-	S 235 JO	
-	A 36	SS 400	260 W	-	-	
-	A 36	SM 400 A/B/C	-	-	-	
Fe 430 B	-	SS 400	-	43 B	S 275 JR	
Fe 430 C	-	-	-	-	S 275 JO	
Fe 430 D1	-	-	-	-	S 275J 2 G3	
Fe 430 D2	-	-	-	-	S 275J 2 G4	
Fe 510 B	A 572 gr. 50	SS490	300 W	50 B	S 355 JR	
Fe 510 C	-	-	350 W	-	S 355 JO	
Fe 510 D1	-	-	-	-	S 355 J 2 G3	
Fe 510 D2	-	-	-	-	S 355 J 2 G4	
Fe 510 DD1	-	-	-	-	S 355 K 2 G 3	
Fe 510 DD2	-	-	-	-	S 355 K 2 G 4	

STEEL SPECIFICATIONS FOR STRUCTURAL PROFILES

American Standard	European Standard	Japanese Standard	South African Standard	Yield Strength	Tensile Strength
Lower strength (for workability and weldability)					
ASTM A 283 gr C	EN 10025 S235JR DIN 17100 RSt 37 -2 BS 4360:gr 40A/B/C	JIS G3101 SS 330	SABS 1431 gr 240WA/C	235 MPa min	340 - 470 MPa
Normal strength (for general use)					
ASTM A 36	EN 10025 S275 JR DIN 17100 RSt 44-2 BS 4360:gr 43 A/B/C	JIS G3101 SS400	SABS 1431 gr 300WA/C	275 MPa min	430 - 550 MPa
Higher strength microalloyed steel					
ASTM A 572 gr 50	EN 10025 S355JR DIN 17100 RRSt 52-2 BS 4360:gr 50A/B/C	JIS G3101 SS490	SABS 1431 gr 350WA/C	355 MPa min	490 - 630 MPa
Weathering steel - for improved corrosion resistance					
Other Standard					
			COR - TEN / A	345 MPa min	480 MPa min

CONVERSION FACTOR TABLES

LENGTH

Inches	Feet	Yards	Miles	Millimeters	Meters
1	0.08333333	0.02777778	0.000157828	25.4	0.0254
12	1	0.3333333	0.0001893939	304.8	0.3048
36	3	1	0.0005681818	914.4	0.9144
63360	5280	1760	1	1,609,344	1,609.344
0.03937008	0.003280840	0.001093613	0.0000006213712	1	0.001
39.37008	3.280840	1.093613	0.0006213712	1,000	1

AREA

Sq. Inches	Sq. Feet	Sq. Yards	Acres	Sq. Miles	Sq. Cm	Sq. Meters	Hectares
1	0.006944444	0.000771605	0.0000229568	0.0000003228	6.4516	0.00064516	0.000064516
144	9	1	0.0002066116	0.0015625	929.0304	0.09290304	0.09290304
1296	43560	4840	640	1	8361.2736	0.8361274	0.8361274
6272640	27878400	3097600	1	1	40468564.2	4046.856	0.4046856
4014489600	0.001076391	0.000119599	0.0002471054	0.000000386102	10,000	2,589,988.11	258.9988
0.1550003	10.76391	1.195990	2.471054	0.003861022	10,000	0.0001	0.0001
1550.003	107639.1	11959.90	24.71054	0.003861022	10,000	10,000	1
15500031.0	107639.1	11959.90	24.71054	0.003861022	10,000	10,000	1

CAPACITY - VOLUME

Cu. Inches	Cu. Feet	Sq. Yards	Liters	Cu. Miles	U.S. Gals	Imp. Gals	Barrel
1	0.0005787037	0.00002143347	0.1638661	0.00001638706	0.004379004	0.03604675	0.1781076
1728	1	0.03703704	28.31605	0.02831684	7.480520	6.228878	4.808905
46656	27	1	764.5335	0.7645549	201.9740	168.1797	128.8136
61.02545	0.03531566	0.001307987	1	0.001000028	0.2641794	0.2199769	0.1700476
61023.74	35.31467	1.307951	999.9720	1	264.1721	219.9708	168.1797
231	0.1336806	0.004951132	3.785306	0.003785412	1	0.8326799	0.672517
277.4175	0.1605426	0.005946021	4.545932	0.004546059	1.200942	1	0.8008206
9702	5.614583	0.2079475	158.9828	0.1589873	42	34.97255	27.31605

WEIGHT

Ounces	Pounds	Short Tons	Long Tons	Kilograms	Metric Tons	Newtons
—	0.0625	0.00003125	0.0000279018	0.02834952	0.00002834952	0.278014
16	—	0.0005	0.0004464286	0.4535924	0.0004535924	4.448222
32000	2000	—	0.8928571	907.1847	0.9071847	8896.444
35840	2240	1.12	—	1016.047	1.016047	9964.017
35.27396	2.204623	0.001102311	0.0009842065	—	0.001	9.806650
35273.96	2204.623	1.102311	0.9842065	1000	—	9806.650
3.596941	0.224809	0.00001124	0.00001004	0.101972	0.00001020	—

WEIGHT PER UNIT OF AREA

Lbs./Sq. Ft.	Lbs./Sq. In.	Kg./Sq. Cm.	Kg./Sq. M.	Short Ton./Sq. Ft.	Pascals	Kilopascals
—	0.006944444	0.0004882428	4.882428	0.005	47.88076	0.047880
144	—	0.07030696	703.0696	0.072	6894.757	6.89476
2048.161	14.22334	—	10.000	1.024081	98066.50	98.06650
0.2048161	0.001422334	0.0001	9764.855	0.00001024081	9.806650	0.0098067
2000	13.88889	0.9764855	0.1019716	—	95760.52	957.6052
0.020885	0.00014504	0.0000102	0.1019716	0.00001044	—	0.001
20.88543	0.145038	0.010197	101.9716	0.0104427	1000	—

FORCE PER UNIT OF AREA, PRESSURE

Kg./Sq. Cm.	Oz./Sq. In.	Lbs./Sq. In.	Mm. Mercury (0°C)	Mm. Mercury (4°C)	In Water (4°C)	Kilopascals	Bar
—	227.5735	14.22334	735.5592	28.95902	393.7118	98.06650	0.980665
0.004394185	—	0.0625	3.232183	0.1272513	1.730042	0.430922	0.004309
0.07030696	16	—	5.171493	2.036021	27.68068	6.894757	0.068948
0.0013595098	0.3093884	0.01933677	—	0.03937008	0.5352550	0.133322	0.001333
0.03453155	7.858465	0.4911541	25.4	0.07355387	13.59548	3.38638	0.033864
0.002539929	0.5780205	0.03612628	1.868268	0.295301	4.014742	0.249082	0.002491
0.0101972	2.320606	0.1450377	7.500638	29.530059	—	—	—
1.019716	232.06056	14.50368	750.06376	—	401.47421	100	—

FORCE PER UNIT OF AREA, PRESSURE

Lbs./Sq. In.	Kips./Sq. In.	Kg./Sq. Mm.	Megapascals
—	0.001	0.00070307	0.00689476
1000	—	0.703070	6.894757
1422.33	1.42233	—	9.80665
145.03768	0.1450377	0.101972	—



GROUP PROFILE

TAURANI HOLDINGS LTD is a multinational conglomerate headquartered in Dubai, United Arab Emirates. It operates in four continents with more than 10,000 employees worldwide. THL was founded in 1976 as a group of manufacturing, trading and servicing companies catering to a vast multitude of sectors across various markets.

With annual turnover of US\$200 Million, the group has gradually ventured into every trade arena through well-defined business strategies. An able leadership and a highly dedicated workforce across the group are the key elements that has engineered its evolution.

As a global enterprise, the group's ability to understand, innovate and operate in a multicultural world ensures its long-term sustainability and, specifically, impacts its ability to meet the group's underlined growth trajectory.

TAURANI GROUP COMPANIES









RAS AL KHOR

P. O. Box : 5993,
Dubai - U.A.E.

T : +971 4 889 0889

**NATIONAL
INDUSTRIES PARK**

P. O. Box : 17045, Dubai - U.A.E.

T : +971 4 889 0880

info@dsssteel.com | www.dsssteel.com